

4098 Detectors, Sensors, and Bases Application Manual



574-709
Rev. T

Copyrights and Trademarks

Copyrights

© 2008- 2011 SimplexGrinnell LP. All rights reserved.

Specifications and other information shown were current as of publication and are subject to change without notice.

Suffix “C” or “CA” following an eight-digit Product ID number denotes ULC-listed product.

Suffix “E” following an eight-digit Product ID number denotes Global product. The second suffix identifies market country, models with this suffix are not UL Listed.

Trademarks

Tyco, IDNet™, Simplex and the Simplex logo are trademarks of Tyco International Ltd. and its affiliates and are used under license.

MAPNET II® Communication Net is protected by US Patent No. 4,796,025.

TrueAlarm® Analog Detection is protected by US Patent No. 5,155,468.

TrueAlarm® Detector Base is protected by US Patent No. 5,173, 683.

All illustrations of actual detectors, sensors, and bases shown in this publication are artist’s renditions.

Cautions and Warnings

Cautions and Warnings



READ AND SAVE THESE INSTRUCTIONS- Follow the instructions in this installation manual. These instructions must be followed to avoid damage to this product and associated equipment. Product operation and reliability depend upon proper installation.



DO NOT INSTALL ANY SIMPLEX® PRODUCT THAT APPEARS DAMAGED- Upon unpacking your Simplex product, inspect the contents of the carton for shipping damage. If damage is apparent, immediately file a claim with the carrier and notify an authorized Simplex product supplier.

ELECTRICAL HAZARD - Disconnect electrical field power when making any internal adjustments or repairs. All repairs should be performed by a representative or authorized agent of your local Simplex product supplier.



STATIC HAZARD - Static electricity can damage components. Handle as follows:

- Ground yourself before opening or installing components.
- Prior to installation, keep components wrapped in anti-static material at all times.

FCC RULES AND REGULATIONS – PART 15 - This equipment has been tested and found to comply with the limits for a Class A digital device pursuant to Part 15 of the FCC Rules. These limits are designed to provide reasonable protection against harmful interference when the equipment is operated in a commercial environment. This equipment generates, uses, and can radiate radio frequency energy and, if not installed and used in accordance with the instruction manual, may cause harmful interference to radio communications. Operation of this equipment in a residential area is likely to cause harmful interference in which case the user will be required to correct the interference at his own expense.

Table of Contents

Copyrights and Trademarks	iii
Copyrights.....	iii
Trademarks.....	iii
Cautions and Warnings	iv
Table of Contents	v
Chapter 1 Overview	1-1
Introduction	1-1
In this Chapter	1-1
Special Considerations.....	1-2
Overview.....	1-2
Special Considerations for Smoke Detectors and Sensors.....	1-2
Smoke Detector/Sensor Applications	1-2
Where to Place Detectors and Sensors	1-3
Proper Locations for Detectors and Sensors	1-3
Where Not to Place Detectors and Sensors.....	1-6
Improper Locations for Detectors and Sensors	1-6
Principles of Operation	1-8
Introduction	1-8
Heat Detector Operation.....	1-8
Photoelectric Smoke Detectors/Sensors	1-8
Ionization Smoke Detectors/Sensors	1-8
Carbon Monoxide Gas Detectors/Sensors	1-8
Chapter 2 4098 Smoke Detectors, Heat Detectors and Bases.....	2-1
Introduction	2-1
In this Chapter	2-1
4098 Smoke Detectors	2-2
Introduction	2-2
Smoke Detector Limitations.....	2-2
Specifications.....	2-3
Mounting Requirements.....	2-4
4098 Heat Detectors.....	2-5
Introduction	2-5
Heat Detector Types.....	2-5
Specifications.....	2-5
4098 Bases.....	2-8
Introduction	2-8
Mounting	2-9
Wiring.....	2-10
Chapter 3 TrueAlarm Sensors, Sensor Bases, and QuickConnect Smoke Sensors	3-1
Introduction	3-1

In this Chapter	3-1
4098 TrueAlarm Sensors.....	3-2
Specifications.....	3-2
Special Applications.....	3-2
Mounting.....	3-2
4098 TrueAlarm Sensor Bases	3-3
Introduction	3-3
Specifications.....	3-3
Setting the Base's Address.....	3-3
Address Setting for the 2120 CDT System.....	3-5
Address Setting for the 4010, 4020, 4100+, 4100U, 4100ES, 4008, or 4120 System.....	3-5
Multi-Sensor Bases 4098-9795 and 4098-9796.....	3-7
Wiring.....	3-7
4098 TrueAlarm QuickConnect Smoke Sensors.....	3-12
Overview.....	3-12
Specifications.....	3-12
Setting the Sensor's Address	3-13
Wiring.....	3-14
Chapter 4 Accessories	4-1
Introduction	4-1
In this Chapter	4-1
Relay Module Accessories	4-2
2098-9737 Relay Module Wiring	4-2
4098-9822 Relay Module Wiring	4-3
Relay Module Installation.....	4-4
Remote LED Module	4-4
Chapter 5 Compatibility and Testing	5-1
Introduction	5-1
In this Chapter	5-1
Compatibility	5-2
Compatibility for 4098 Detectors and Detector Bases.....	5-2
Maintenance and Testing	5-4
Maintenance	5-4
Preferred Method of Testing Smoke Detectors/Sensors.....	5-4
Test Equipment Available.....	5-4
Alternate Method for Testing Sensors.....	5-5
Magnetic Test for Photoelectric Detectors.....	5-5
Magnetic Test for Ionization Detectors	5-7
Ion Detector Sensitivity Test.....	5-7
Cleaning.....	5-8
Introduction	5-8
Photoelectric Smoke Detector/Sensor Cleaning	5-8
Special Considerations for Ion Detectors and Sensors.....	5-8
Trouble Indications	5-9
Trouble Indications for TrueAlarm Sensors.....	5-9
Trouble Indications, <i>Continued</i>	5-10

Fire Alarm Trouble and Maintenance Log	5-11
Fire Alarm Trouble and Maintenance Log	5-11
Index	I-1

Chapter 1 Overview

Introduction

The purpose of this publication is to provide information concerning the proper application of both heat and smoke detectors/sensors in conjunction with fire alarm systems.

The information in this publication is intended to be used only as a technical guide. The requirements of applicable codes and standards, as well as directives of Authorities Having Jurisdiction (AHJ's), should be followed.

In this Chapter

Refer to the page number listed in this table for information on a specific topic.

Topic	See Page #
Special Considerations	1-2
Where to Place Detectors and Sensors	1-3
Where Not to Place Detectors and Sensors	1-6
Principles of Operation	1-8

Special Considerations

Overview

Before installing detectors/sensors, make a survey of the area to be covered in accordance with information provided in NFPA 72, (an excerpt of which is provided in the “Smoke Detector/Sensor Applications” section below). For additional information, refer to NFPA 72 and the *NEMA Guide for Proper Use of System Smoke Detectors*.

Special Considerations for Smoke Detectors and Sensors

- Is there human occupancy?
 - Contents to be protected.
 - Type of construction and use.
 - Burning characteristics of contents.
 - Air movement - stratification.
 - Deflections and obstructions.
 - Height of ceilings.
 - Surface conditions of ceilings.
 - Type of ceiling construction.
 - Total area.
 - Vent locations - velocities - dilution.
-

Smoke Detector/Sensor Applications

Each detector/sensor is capable of providing up to 900 square feet (84 square meters) of coverage, depending on the following:

- Requirements of local codes.
 - Results of engineering evaluation.
-

Where to Place Detectors and Sensors

Proper Locations for Detectors and Sensors



IMPORTANT: The guidelines in this section are adapted from standards published by the National Fire Protection Association, Quincy, Massachusetts, U. S. A. These standards include NFPA 72, “National Fire Alarm Code”; NFPA 70, “National Electrical Code”, Article 760; and NFPA 90A, “Standard for the Installation of Air Conditioning and Ventilating Systems.”

To provide effective early warning of a developing fire situation, smoke detectors/sensors should be installed in all areas of the protected premises. Total coverage as defined by NFPA 72 should include all rooms, halls, storage areas, basements, attics, lofts, and spaces above suspended ceilings including plenum areas utilized as part of the HVAC system. In addition, this should include all closets, elevator shafts, enclosed stairways, dumbwaiter shafts, chutes and other subdivisions and accessible spaces.

Fire detection systems installed to meet local codes or ordinances may not be adequate for early warning of the fire. Some codes or ordinances have minimum objectives such as capturing elevators or preventing circulation of smoke through HVAC systems instead of early detection of fire.

You should weigh the costs against the benefits of installing a complete fire detection system when any detection system is being installed. The location, quantity and zoning of detectors/sensors should be determined by what objectives are desired rather than the minimum requirements of any local codes or ordinances.

Detectors/sensors may be omitted from combustible blind spaces when any of the following conditions prevail:

- Where the ceiling is attached directly to the underside of the supporting beams of a combustible roof or floor deck.
- Where the concealed space is entirely filled with noncombustible insulation. (In solid joist construction, the insulation need only fill the space from the ceiling to the bottom edge of the joist of the roof or floor deck.)
- Where there are small concealed spaces over rooms, provided the space in question does not exceed 50 square feet (4.6 square meters).
- In spaces formed by sets of facing studs or solid joists in walls, floors, or ceilings where the distance between the facing studs or solid joists do not exceed 6 inches (15 cm).

Detectors/sensors may also be omitted from below open grid ceilings where all of the following conditions are met:

- The openings of the grid are at least 1/4 inch (6 mm) in the smallest dimension.
- The thickness of the material does not exceed the smallest of the grid openings.
- The openings constitute at least 70% of the area of the ceiling material.

Continued on next page

Where to Place Detectors and Sensors, *Continued*

Proper Locations for Detectors and Sensors

Detectors/sensors are usually required or recommended underneath open loading docks or platforms and their covers, and in accessible under-floor areas in buildings without basements. Detectors/sensors may be omitted from combustible blind spaces when all of the following conditions prevail:

1. The space is not accessible for storage purposes, it is protected against the entrance of unauthorized persons, and it is protected against the accumulation of windblown debris.
2. The space contains no equipment/structures (such as steam pipes, electrical wiring, ducts, shafts, or conveyors) that could potentially ignite or conduct the spread of fire.
3. The floor over the space is tight.
4. Non flammable liquids are processed, handled, or stored on the floor above the space.

“Total coverage” as described in NFPA 72, is the definition of a complete fire detection system. In some of the specified areas of coverage, such as attics, closets, under open loading docks or platforms, a heat detector may be more appropriate than a smoke detector. Careful consideration should be given to the detector manufacturer’s instructions and the following recommendations in this guide.

In general, when only one detector/sensor is required in a room or space, the detector/sensor should be placed as close to the center of the ceiling as possible. Central location of the detector/sensor is best for sensing smoke and/or fire in any part of the room. If a center location is not possible, it may be placed no closer than 4 inches (10 cm) from the wall, or if listed for wall mounting, it may be mounted on the wall. Wall mounted detectors/sensor should be located approximately 4 to 12 inches (10 to 30 cm) from the ceiling to the top of the detector, and at least 4 inches (10 cm) from any corner wall junction (see the figure below).

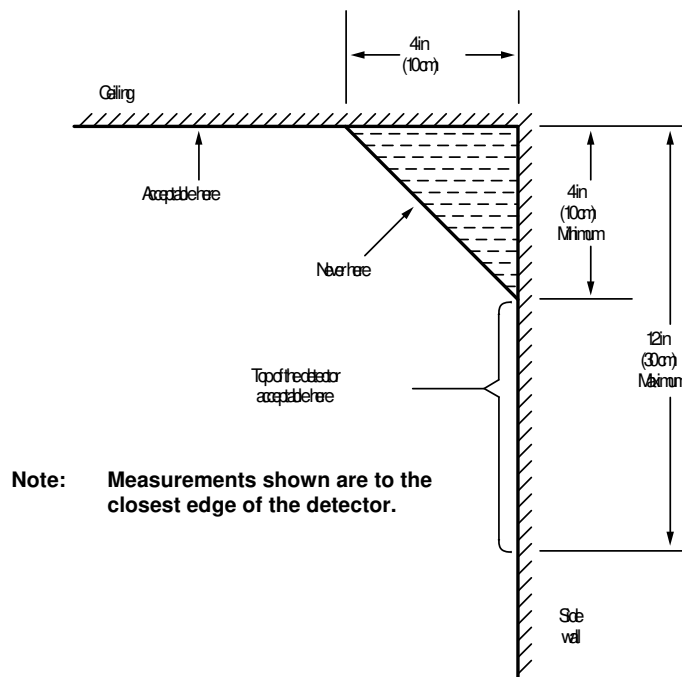

Figure 1-1. Wall and Ceiling Mounted Detector/Sensor

Continued on next page

Where to Place Detectors and Sensors, *Continued*

Proper Locations for Detectors and Sensors

When an air supply and/or an air return duct opening is present in a room or space, the detector/sensor(s) should be placed in the path of the air flow toward the return air duct opening (see below).

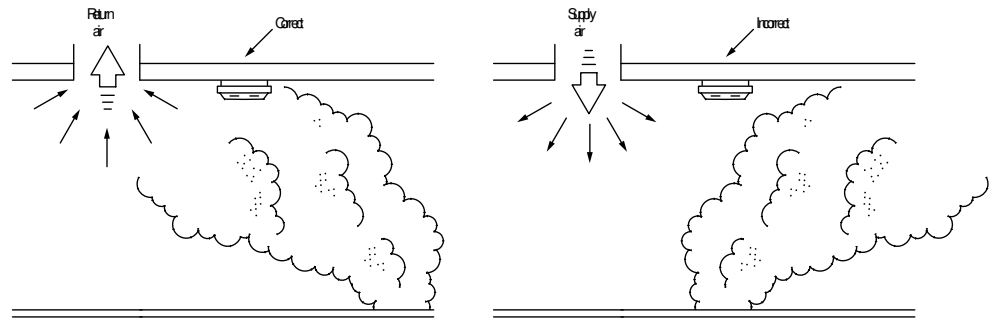

Figure 1-2. Detector Placement - Air Supply and/or Return Ducts

Smoke tests are helpful in determining proper placement. Special attention should be given to smoke travel directions and velocity, since either can affect detector/sensor performance.

Placement of a detector/sensor near air conditioning or incoming air vents can also cause excessive accumulation of dust and dirt on the detector/sensor. This dirt can cause the detector/sensor to malfunction and cause nuisance alarms. Detectors/sensors should not be located closer than 3 feet (0.9 m) from an air supply diffuser.

Spot type detectors/sensors in properly engineered systems, may also be placed in return air ducts, or in approved duct detector housings designed for this application. Although duct detectors are not a substitute for open area detectors, they can provide an effective method of initiating building control functions to prevent smoke from being transported from the fire area to other parts of a building.

Where Not to Place Detectors and Sensors

Improper Locations for Detectors and Sensors

One of the major causes of nuisance alarms is improper placement of detectors/sensors. The best way to avoid nuisance alarms is to not install detectors/sensors in environments that can cause them to malfunction. See the table and examples provided below.

Table 1-1. Environmental Conditions that Influence Detector Response*

Detection Protection	Air Velocity >300 ft. (91.4m)/min.	Atm. Pressure 3000 ft. (914m) Above Sea Level	Humidity >93% RH	Temp. <32°F (0°C) >100°F (38°C)	Color of Smoke
Ion	X	X	X	X	O
Photo	O	O	X	X	X
Beam	O	O	X	X	O
Air Sampling	O	O	X	X	O

* See Table A-5-3.6.1.1 in NFPA 72

X = May affect detector/sensor response

O = Generally does not affect detector/sensor response

DO NOT PLACE DETECTORS/SENSORS:

- In excessively dusty or dirty areas, such as feed rooms, steel mills, etc. Dust and dirt can accumulate on the detector/sensor's sensing chamber and make it overly sensitive, or block the air entrances to the sensing chamber and make the detector/sensor less sensitive to smoke. Be especially careful to avoid areas where fumigants, fog or mist-producing materials, or sweeping and cleaning compounds are used. These substances may cause nuisance alarms.
- Outdoors, in stables, open storage sheds, or other open structures affected by dust, air currents, or excessive humidity and temperature.
- In damp or excessively humid areas, or next to bathrooms with showers. Water droplets can accumulate inside the sensing chamber and make the detector/sensor overly sensitive. A tremendous amount of humid air is produced during a hot shower. The moisture in this humid air can enter the sensing chamber as water vapor, then cool and condense into droplets that can cause a nuisance alarm.
- In elevator lobbies over ashtrays or where people smoke while waiting for the elevator.
- In very cold or very hot environments, or in unheated buildings or rooms where the temperature can fall below or exceed the operating temperature range of the detector/sensor. At temperatures below 32° F (0° C), ice crystals or condensation can appear inside the sensing chamber and make it overly sensitive or cause a nuisance alarm. At temperatures above the operating range of the detector/sensor greater than 120° F (49° C), its internal components may not function properly.
- In or near areas where combustion particles are normally present, such as in kitchens or other areas with ovens and burners; in garages, where particles of combustion are present in vehicle exhausts; within 15 feet (4.5 meters) of any type of furnace, hot water heater, or gas space heater; or in welding shops or other types of work areas where some form of combustion is used in the activity normally conducted in that area. When a detector must be located in or adjacent to such an area, a fixed temperature heat detector may be appropriate.

Continued on next page

Where Not to Place Detectors and Sensors, *Continued*

Improper Locations for Detectors and Sensors

- In air streams passing by or through kitchens. Air often enters a residence or a residential unit of an apartment building through cracks around the front and/or back doors. If the air return is in the bedroom hallway or in the bathroom, and if air from the kitchen easily enters the air stream going from the door to the air return, combustion particles from cooking can cause nuisance alarms. Install detectors/sensors so that they protect the bedrooms, but so they are out of the air stream.
- In or near manufacturing areas, battery rooms, or other areas where substantial quantities of vapors, gases or fumes may be present. Strong vapors, like excessive humidity, can make detectors/sensors overly sensitive or less sensitive than normal. In very large concentrations, gases heavier than air, such as carbon dioxide, may make detectors/sensors more sensitive, while gases lighter than air, such as helium, may make them less sensitive. Aerosol particles may collect on detector/sensor chamber surfaces and cause nuisance alarms.
- Insect-infested areas. If insects enter a detector/sensor's sensing chamber, they can cause a nuisance alarm. Take proper insect eradication procedures before installing detectors/sensors in such locations. If spraying is done, do not allow insect spray to enter the detectors/sensors.
- Near fluorescent light fixtures. Electrical noise generated by fluorescent light fixtures may cause nuisance alarms. Install detectors/sensors at least 1 foot (0.3 meters) away from such light fixtures.
- When using the CO Base for CO fire detection, do not install in locations that could have potentially high non-fire levels of CO.

Underwriters Laboratories (UL) has three standards for smoke detectors: one for duct detectors/sensors, UL 268A; one for single and multiple station detectors/sensors, UL 217; and one for system type detectors/sensors, UL 268. Detectors/sensors should only be used in the applications for which they are specifically listed.

The NFPA 101 Life Safety Code states that single station smoke detectors shall sound an alarm only within an individual living unit or similar area and shall not actuate the building fire alarm system. It also states, "All systems and components shall be approved for the purpose for which they are installed."

In addition to possible code noncompliance, the following deficiencies would exist in a series of residential smoke detectors connected in a fire alarm system mode:

- Since the fire alarm system is not supervised, vandals or others could disconnect a detector or the entire system, leaving a building without protection. The residents would be unaware of the serious life threatening condition.
- Residential detectors do not latch in alarm. In other words, the detector self-resets. One detector in alarm sounds all the detectors connected together. It would be difficult to identify or locate a specific detector that initially put the system into alarm after the alarm condition was cleared.

System detectors/sensors latch in alarm. They do not reset until power is momentarily disconnected. This makes it convenient to identify the location of the detector/sensor that caused the control panel to alarm. In addition, system detectors are specifically designed to connect to a supervised control panel. Two-wire detectors require a UL compatibility review to verify that the detector and panel properly operate together. A typical life safety fire alarm system for an apartment complex would be to use system detectors/sensors and manual fire alarm stations in the hallways and common areas of the complex and residential single station type detectors and heat detectors in the individual apartments. The system detectors/sensors, manual stations and heat detectors would be connected to a supervised control panel, sound a general alarm and automatically notify the proper authorities that a fire condition exists. The residential detectors located in the apartments would be interconnected only within the individual living quarters of each apartment. These residential units would sound an alarm only in the apartment unit.

Principles of Operation

Introduction

This section describes how the different types of detectors and sensors work. For additional information on TrueAlarm sensor operation, refer to the *TrueAlarm Concepts* publication (PER-91-024).

Heat Detector Operation

The heat detector senses the heat or the **Rate-of-Rise (ROR)** in the air temperature of the environment in which it is located. The heat detector is comprised of electronic circuitry and a mechanical package that is designed to sense the ROR of the air temperature in an expedient and reliable fashion. Upon detection of an abnormal increase in air temperature, or ROR in air temperature, the electronics indicate an alarm by increasing the amount of current draw from the monitor zone it is connected to. The monitor zone is a supervised detection circuit that is tied back to a main control panel that takes appropriate action to indicate an alarm has been reported, if the zone current is substantially increased.

Being of an electronic design, the temperature of the air is sensed by using two negative temperature coefficient thermistors. The resistance of the thermistors goes down with an increase in temperature. One thermistor is placed in a position such as to sense the open air temperature very rapidly (RT1). The second thermistor is positioned in a small cavity that protrudes out from the main body of the detector (RT2). The location of RT2 allows for fast detection of a quick change in the air temperature, but yet for a slow or medium rate of temperature change, the detector does not trip due to the ROR feature. For a slower change in temperature, the detector trips into alarm due to a set fixed temperature that is sensed by RT1. For a fast temperature rise, when a difference in temperature sensed by RT1 and RT2 has reached a predetermined amount, the detector trips into alarm.

Photoelectric Smoke Detectors/Sensors

These devices operate on a light scattering principle. The smoke sensing chamber contains an infrared LED source with a peak spectral emission of 880 nanometers. This source is placed at an angle from a spectrally matched photodiode receiver. During a NO SMOKE condition, only light reflected from the chamber walls enters the receiver and shows up as a small photocurrent. As smoke particles enter the sensing chamber and cross the light beam of the LED, more light reaches the receiver due to scattering. The receiver circuitry converts this photocurrent into a signal voltage. In a detector, when this voltage reaches a preset level, an alarm is produced. In a sensor, this signal voltage goes into an 8-bit, A to D (analog to digital) converter. A digital representation of this signal voltage is then transmitted to the fire alarm panel for further processing.

Ionization Smoke Detectors/Sensors

These devices use a small radiation source, Americium-241, which emits alpha particles that ionize air molecules between two electrically charged electrodes. With the application of a DC voltage to these electrodes, a small ionization current flows within the chamber. As smoke enters the chamber, a decrease in ionization current results. This current is converted into a signal voltage by a transimpedance circuit. In a detector, when this signal voltage drops below a preset level, an alarm is produced. In a sensor, this signal voltage goes into an 8-bit A to D (analog to digital) converter. A digital representation of this signal voltage is then transmitted to the fire alarm panel for further processing.

Carbon Monoxide Gas Detectors/Sensors

The CO Sensor and Sounder Bases with a CO Replaceable Sensor (CRS) module work in conjunction with existing detector heads. The CO Sensor Base enhances fire detection and provides the ability to combine fire and toxic gas leakage detection in a single device. The CO sensor measures the concentration of carbon monoxide gas in the air in part per million (PPM). When toxic gas operation is selected, the FACP panel may generate either a supervisory, utility or priority 2 alarms. The alarm level is calculated within the panel based on the time integrated CO levels that have been measured at the detector.

Chapter 2

4098 Smoke Detectors, Heat Detectors and Bases

Introduction

This chapter contains specification and mounting information for 4098 Smoke Detectors, Heat Detectors, and Bases.

In this Chapter

Refer to the page number listed in this table for information on a specific topic.

Topic	See Page #
4098 Smoke Detectors	2-2
4098 Heat Detectors	2-5
4098 Bases	2-8

4098 Smoke Detectors

Introduction



CAUTION: Install the detectors described in this publication in accordance with applicable NFPA standards, local codes, and the Authorities Having Jurisdiction (AHJs). Failure to follow these instructions may result in failure of the detector to initiate an alarm condition. The manufacturer is not responsible for detectors that have been improperly installed, tested, or maintained.

Smoke Detector Limitations

The smoke detectors used with these bases are designed to activate and initiate emergency action, but do so only when used in conjunction with other equipment. They are designed for installation in accordance with NFPA 72 National Fire Alarm Code.

- Smoke detectors do not work without power. AC or DC powered smoke detectors do not work if the power supply is cut off for any reason.
- Smoke detectors do not sense fires when smoke does not reach the detectors. Smoke from fires in chimneys, in walls, on roofs or on the other side of closed doors may not reach the smoke detector and alarm it.
- A detector may not detect a fire developing on another level of a building. For this reason, detectors should be located on every level of a building.
- Smoke detectors have sensing limitations. Ionization detectors are better at detecting fast, flaming fires than slow, smoldering fires. Photoelectric detectors sense smoldering fires better than flaming fires. Because fires develop in different ways, and are often unpredictable in their growth, neither type of detector is always best, and a given detector may not always provide warning of a fire. In general, detectors cannot be expected to provide warning for fires resulting from inadequate fire protection practices, violent explosions, escaping gases, improper storage of flammable liquids like cleaning solvents, other safety hazards, or arson.
- Smoke detectors cannot last forever. Smoke detectors contain electronic parts. Even though detectors are made to last for many years, any of these parts could fail at any time. Therefore, test your smoke detector system per NFPA 72 at least annually. Clean and take care of your smoke detectors regularly. (See Chapter 5 of this publication for cleaning instructions.)

Continued on next page

4098 Smoke Detectors, *Continued*

Specifications

Table 2-1. Smoke Detector Specifications

Specifications	Smoke Detector Data		
Detector PID (4098)	-9601, -9605	-9602	-9603
Type of Detector	Photoelectric	Photoelectric with Heat	Ionization
Working Voltage (2-wire)	8.5 – 33 VDC	8.5 – 33 VDC	8.5 – 33 VDC
Rated Voltage (4-wire)	15 – 32 VDC	15 – 32 VDC	15 – 32 VDC
Input Ripple Voltage	25% Max.	25% Max.	25% Max.
Max. Alarm Current	86 mA	86 mA	86 mA
Surge Current	<200 μ A	<200 μ A	<200 μ A
Standby Current	<100 μ A	<100 μ A	<100 μ A
Heat Element Rating	N/A	135° F	N/A
Humidity Range (Non-Condensing)	10-95% RH	10-95% RH	10-95% RH
Air Velocity Range	0-2000 FPM	0-2000 FPM	0-200 FPM

Continued on next page

4098 Smoke Detectors, *Continued*

Mounting Requirements



All smoke detectors identified in Table 2-1 mount to a detector base (refer to the “4098 Bases” section of this chapter for more information). Use the following considerations and Figure 2-1 when mounting smoke detectors.

IMPORTANT: Smoke must enter the chamber of the detector. Thus, air flow, air stratification, air velocity, air stagnation, and air migration affects detector efficiency.

Note: Where the possibility of positive airflow from the electrical conduit/junction box exists, seal the conduit openings with 3M Weatherban #606 (or equivalent), a non-flammable sealing compound.

- Do not install detectors in areas where temperatures are likely to exceed 100° F (38° C) or fall below 32° F (0° C).
 - Because the 4098-9602 detector combines heat sensing, DO NOT install this detector in locations where the ambient temperatures exceed 100° F (38° C) or where temperature fluctuations above 6° F/min. occur.
 - Do not install detectors on a ceiling within 4 inches (10 cm) of a wall.
 - Do not install detectors where forced air ventilation may dilute the smoke before it reaches the detector.
 - Do not install detectors in areas where smoke is normally present (kitchens, furnace rooms, laundry rooms, loading docks, rooms with fireplaces, rooms with candles, soldering rooms, etc.).
 - Do not install detectors in areas where there is likely to be steam (in hospital patient rooms with vaporizers, near shower rooms, above large sinks, etc.).
 - Do not install detectors above ashtrays in elevator lobbies.
 - Wall-mounted detectors should be located 4 to 12 inches (10-30.5 cm) from the ceiling to detector head.
 - Protect all detector heads during construction to avoid infiltration of construction debris. Remove any protective covers before activating the system.
 - If using the adapter plate, tighten the mounting screws without warping the adapter plate.
-

4098 Heat Detectors

Introduction

This section contains general notes, specifications, and mounting information for the heat detectors shown in Table 2-2.



WARNING: Heat detectors are NOT life-safety devices; USE HEAT DETECTORS FOR PROPERTY PROTECTION ONLY! For life-safety requirements, use smoke detectors.

Notes:

- For all heat detectors, provide electronic supervision with battery back-up at the fire alarm control panel.
- Where the possibility of positive airflow from the electrical conduit/junction box exists, seal the conduit openings with 3M Weatherban #606 (or equivalent), a non-flammable sealing compound.
- Refer to NFPA 72 for application, test, and maintenance requirements.

Heat Detector Types

Fixed Temperature Heat Detectors:

Electronic fixed temperature heat detectors use a fast response, thermistor based design to provide temperature sensing that quickly, accurately, and consistently identifies when fixed temperatures are exceeded. For this reason, the fixed temperature detectors are recommended for most applications. With a UL spacing distance of 60 X 60 feet, the fixed temperature electronic heat detectors replace **both** mechanical fixed as well as mechanical ROR heat detectors.

ROR Temperature Heat Detectors:

Electronic Rate-of-Rise (ROR) heat detectors detect fixed temperature alarm thresholds the same as the fixed temperature heat detectors, plus detect a ROR alarm with a patented ROR detection design that can quickly respond to sudden temperature variations. Due to the nature of the fast response to temperature changes, care must be taken for proper installation of ROR heat detectors. ROR heat detectors should be installed in stable environmentally controlled areas. These detectors must not be installed where hot or cold air can be blown on them (near ductwork, industrial equipment, air vents etc.). ROR detectors should not be installed where more than 6° F per minute temperature changes can normally occur.

Specifications

Features:

- Rate-of-Rise and Fixed Temperature (see Table 2-2)
- Alarm LED
- Compatible with 2-Wire Initiating Device Circuits
- Current-Limited Alarm State

Electrical Specifications:

- Typical Standby Current - 80 Microamps
- Typical Alarm Current - 40 Milliamps
- Maximum Current - 80 Milliamps while in alarm state
- Operating Range - 15-32 VDC
- Maximum Ripple Voltage Allowed - 30%

Continued on next page

4098 Heat Detectors, *Continued*

Specifications

Table 2-2. Heat Detector Models and Features

Detector Model	Rating or Class*	Area / Language	Color Code
4098-9612 (UL)	135° F (57° C) FT	English	—
4098-9613 (UL)	135° F (57° C) FT and RR	English	—
4098-9614 (UL)	200° F (93° C) FT	English	White
4098-9615 (UL)	200° F (93° C) FT and RR	English	White
4098-9616E	A1	European	Green
4098-9617E	C	European	Red
4098-9618E	A	Australian	White
4098-9619E	B	Australian	Blue
4098-9621E	D	Australian	Red
4098-9622E	I	Chinese	Green
4098-9624E	134° F (56.7° C) FT	Korean	—
4098-9625E	134° F (56.7° C) FT and RR	Korean	—
4098-9626E	134° F (56.7° C) FT	Taiwanese	—
4098-9627E	134° F (56.7° C) FT and RR	Taiwanese	—
4098-9628E	190° F (87.8° C) FT	Korean	—
4098-9629E	190° F (87.8° C) FT and RR	Korean	—
4098-9630E	190° F (87.8° C) FT	Taiwanese	—
4098-9631E	190° F (87.8° C) FT and RR	Taiwanese	—

* RR abbreviates Rate-of-Rise; FT abbreviates Fixed-Temperature.

Continued on next page

4098 Heat Detectors, *Continued*

Specifications

All heat detectors identified in the table below mount to a detector base (refer to the “4098 Bases” section of this publication for more information). Use the information in Figure 2-1 when mounting.

Table 2-3. Heat Detector Specifications

Product ID	Description	Application	Max. Spacing Allowed (UL)	FM
4098-9612	Fixed-Temp. Only, 135° F (57° C)	Unusually violent temp. fluctuations and ceiling temperatures not exceeding 100° F (38° C)	70 X 70 ft (21 X 21 m)	RTI = Quick 20 X 20 ft (6.1 X 6.1 m)
4098-9613	Fixed-Temp. and Rate-of-Rise, 135° F (57° C)	Normal temp. fluctuations and ceiling temperatures not exceeding 100° F (38° C)	70 X 70 ft (21 X 21 m)	RTI = Quick 20 X 20 ft (6.1 X 6.1 m)
4098-9614	Fixed-Temp. Only, 200° F (93° C)	Unusually violent temp. fluctuations and ceiling temperatures exceeding 100° F (38° C) but not 150° F (68° C)	70 X 70 ft (21 X 21 m)	RTI = Quick 20 X 20 ft (6.1 X 6.1 m)
4098-9615	Fixed-Temp. and Rate-of-Rise, 200° F (93° C)	Normal temp. fluctuations and ceiling temperatures exceeding 100° F (38° C) but not 150° F (68° C)	70 X 70 ft (21 X 21 m)	RTI = Ultra Fast 50 X 50 ft (15.2 X 15.2 m)

4098 Bases

Introduction

The 4098-9788 base is designed to be used with 4098 Series smoke and heat detectors, as well as the *QuickConnect2* photo sensor. To use a 4-wire configuration, you must use the 4098-9682 relay base. Heat detectors require the 4098-9684 base when used with a remote LED. This section only covers the information necessary to mount and wire these base configurations. Before installing these bases, make a survey of the area to be covered in accordance with information provided in NFPA 72. For additional information, refer to the *NEMA Guide for Proper Use of System Smoke Detectors*.



CAUTION: Install the bases in this section in accordance with applicable NFPA standards, local codes, and Authorities Having Jurisdiction (AHJs). Failure to follow these instructions may result in failure of the detector to initiate an alarm condition. The manufacturer is not responsible for detectors that have been improperly installed, tested, or maintained.

Continued on next page

4098 Bases, Continued

Mounting

The 4098-9788 base mounts to a 4-inch octagonal, 4-inch square, or single gang electrical box. When mounting to a 4-inch square or any surface mounted box, the 4098-9832 adapter plate kit must be used.

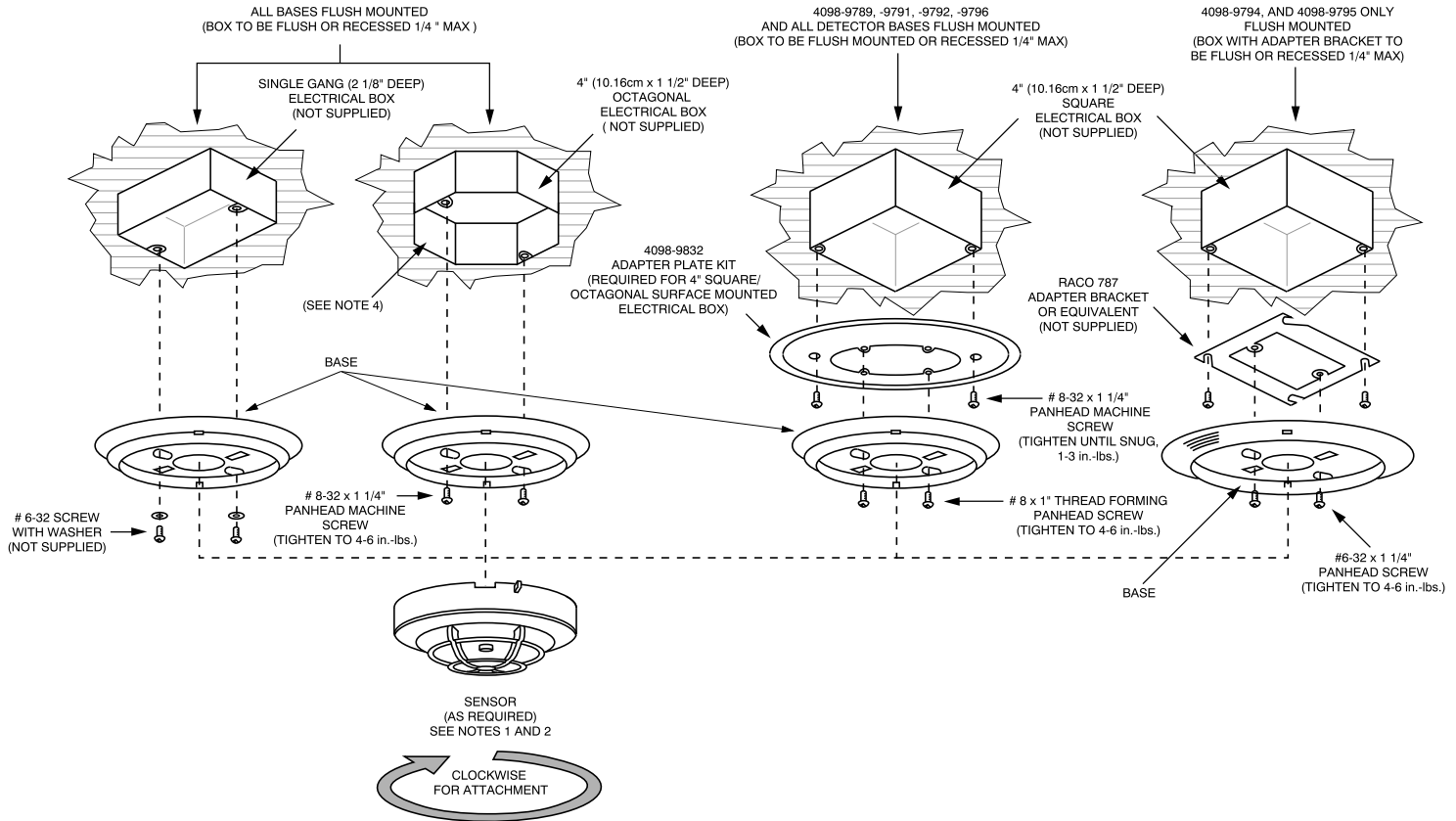

Figure 2-1. Typical Detector/Sensor Mounting

Notes:

1. Break off plastic lock tab to engage locking mechanism. To lock detector/sensor into base, turn unit until the locking tab clicks into place. To unlock detector/sensor, insert the blade of a screwdriver into this slot and then pull down on handle. This action allows the detector/sensor to be turned and removed (see Figure 2-1).
2. Refer to the "Compatibility and Testing" chapter of this publication for detailed information on compatible detectors/sensors.
3. Bases with relay modules require a 1 1/2-inch extension ring (not supplied) mounted to the 4-inch square or octagonal electrical box to meet the space requirement of the relay cube and its wires. The relay module(s) cannot be used in single-gang electrical box installations. The relay cube 4098-9822 must be installed in the electrical box directly behind the sensor base.
4. Use Adapter Plate Kit 4098-9832 when mounting the 4098-9794 and 4098-9795 to a surface mounted 4-inch square or octagonal box. Adapter plates must be installed with textured side towards the electrical box for this installation only.

Continued on next page

4098 Bases, *Continued*

Wiring

All screw terminals accommodate 14 to 18 AWG solid or stranded wire. **When tightening screws, the range of torque is 8 to 12 in-lbs.** Connect wiring to the terminals shown in the figure below. (Figures 2-2 through 2-6 show typical wiring applications for the 4098 bases.)



CAUTION: Do not loop wire under terminals. Break wire run to provide supervision of connections.

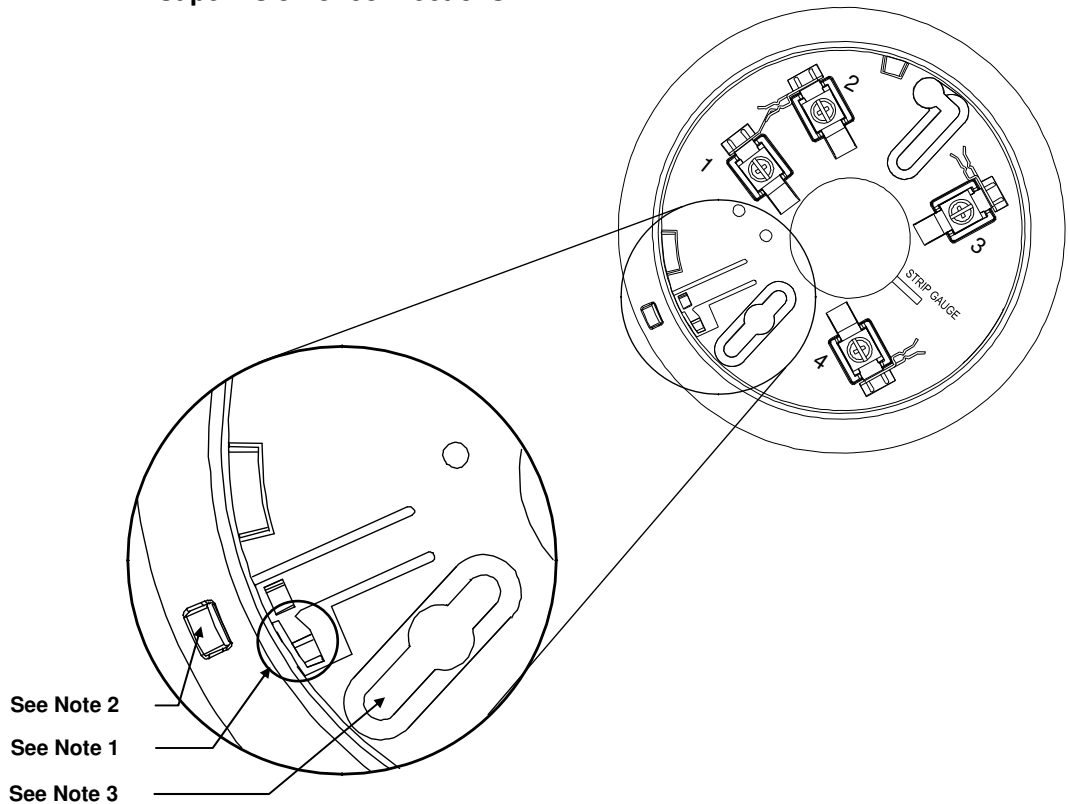

Figure 2-2. Wiring and Mounting the Bases

Notes:

1. Break off plastic tab where indicated to engage locking mechanism.
2. Once locking mechanism is engaged, you must insert a flat-head screwdriver in slot indicated to release the detector from the base.
3. Use the slotted hole indicated for the first screw when mounting the base.

Continued on next page

4098 Bases, *Continued*

Wiring

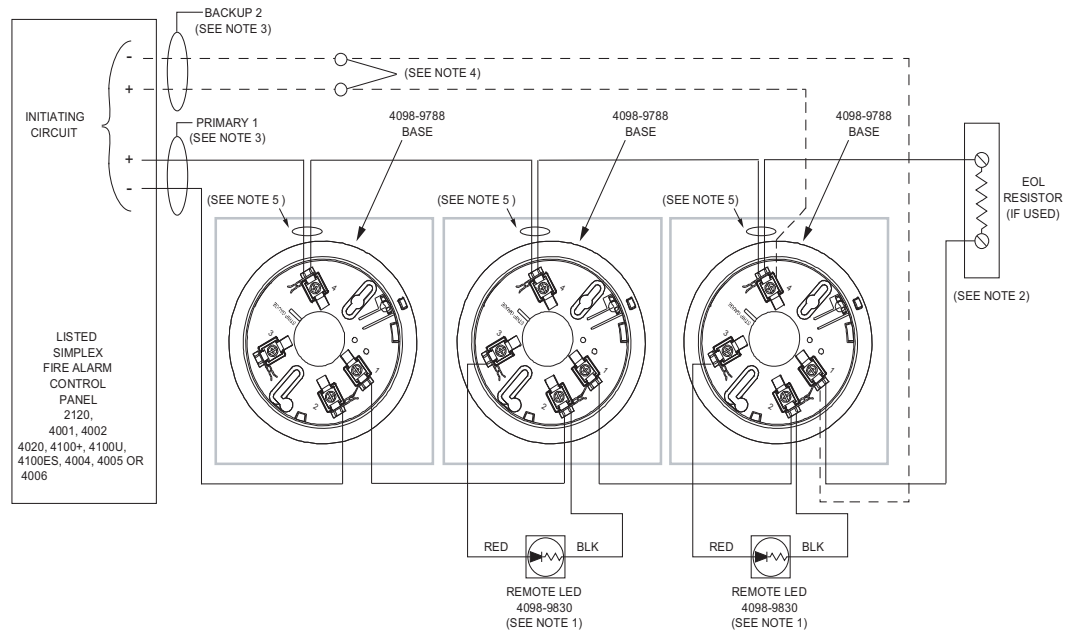

Figure 2-3. 4098-9788 Base Connections for Style B or D Initiating Circuits

Notes:

1. If used, 4098-9830 Remote LED is polarized. Refer to Figure 2-6 to wire remote LED to the Heat Detector; observe color-coded wiring.
2. Refer to wiring diagrams provided with system panel for proper End-Of-Line (EOL) resistor value.
3. It is recommended that the Primary-1 and the Backup-2 lines be in separate wire runs and in compliance with local requirements.
4. For Style D initiating circuit, wire per dotted lines and do not use EOL resistor.
5. Break wires before connecting to Terminal 4 to maintain supervision. Do not loop wire underneath Terminal 4.

Continued on next page

4098 Bases, Continued

Wiring

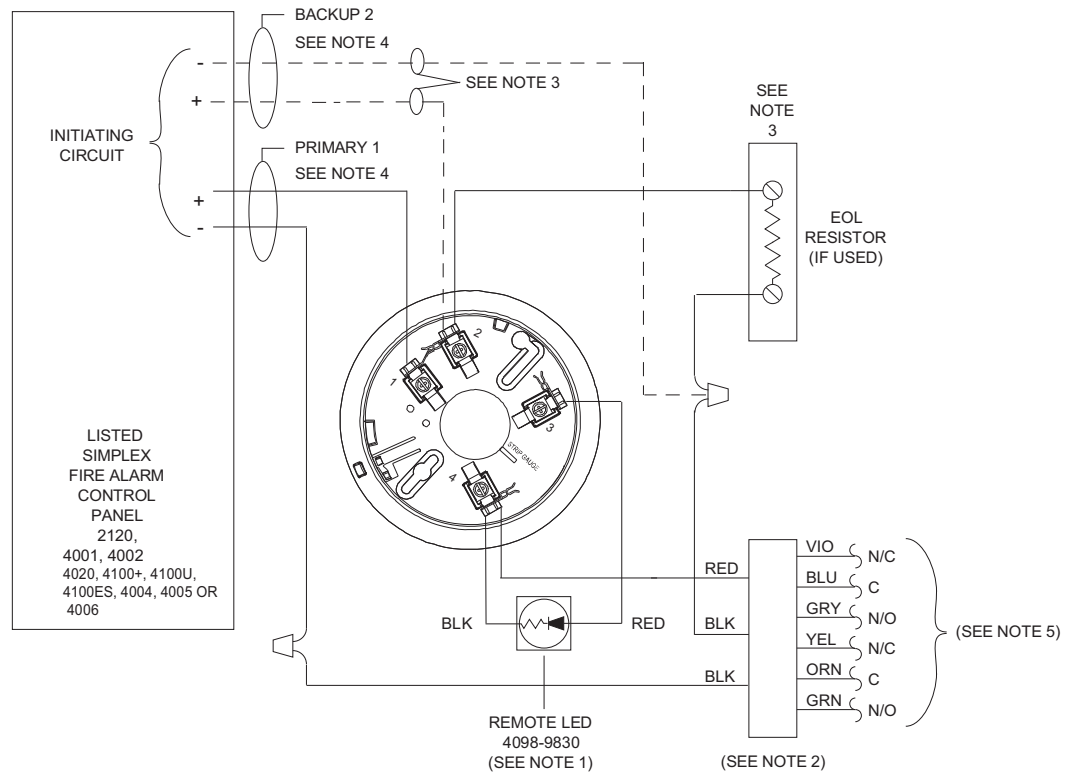

Figure 2-4. 4098-9683 2-Wire Relay Base Connections for Style B or D Initiating Circuits

Notes:

1. If used, 4098-9830 remote LED is polarized; refer to Figure 2-6 to wire remote LED to a heat detector, observe color-coded wiring.
2. Wire only one relay base per initiating circuit.
3. For Style D initiating circuit, wire per dotted lines and do not use EOL resistor. If Style B initiating circuit, refer to wiring diagrams provided with the system panel for proper EOL resistor value.
4. It is recommended that the Primary-1 and the Backup-2 lines be in separate wire runs and in compliance with local requirements.
5. Aux. Relay contacts, each rated 1 amp at 28 VDC/0.5 amp at 125 VAC, resistive.

Continued on next page

4098 Bases, Continued

Wiring

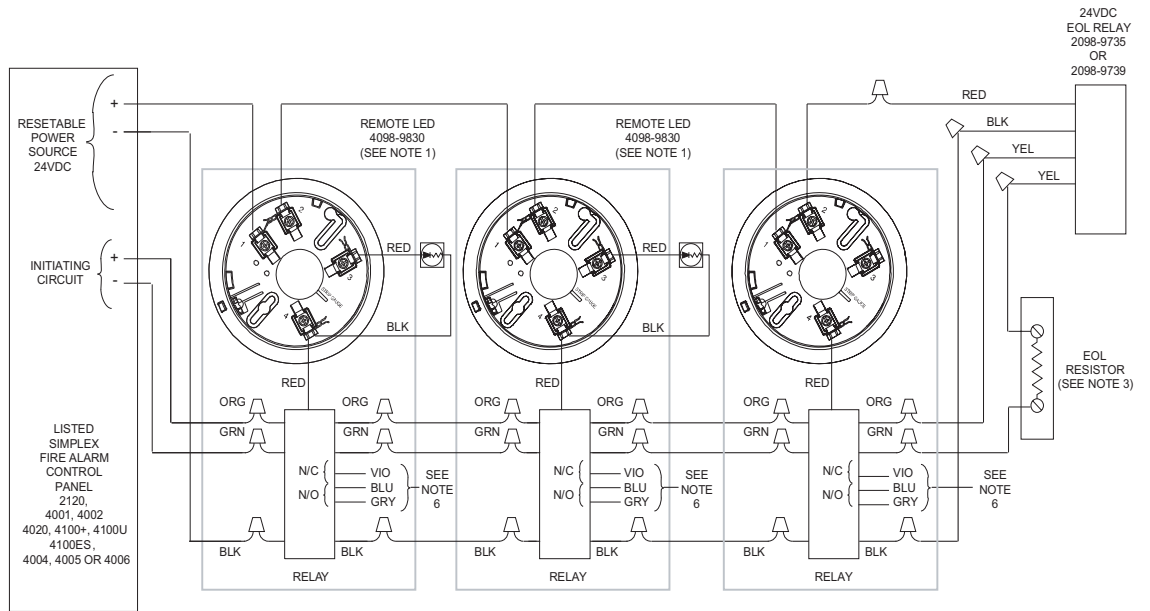

Figure 2-5. 4098-9682 4-Wire Base Connections for Style B Initiating Circuits

Notes:

1. If used, 4098-9830 remote LED is polarized, observe color-coded wiring. (Refer to Figure 2-6 to wire remote LED to heat detector.)
2. Aux. Alarm contacts - Form C - each rated 3 amps at 28 VDC/115 VAC, resistive.
3. Refer to wiring diagrams provided with system panel for proper EOL resistor value.

Continued on next page

4098 Bases, Continued

Wiring

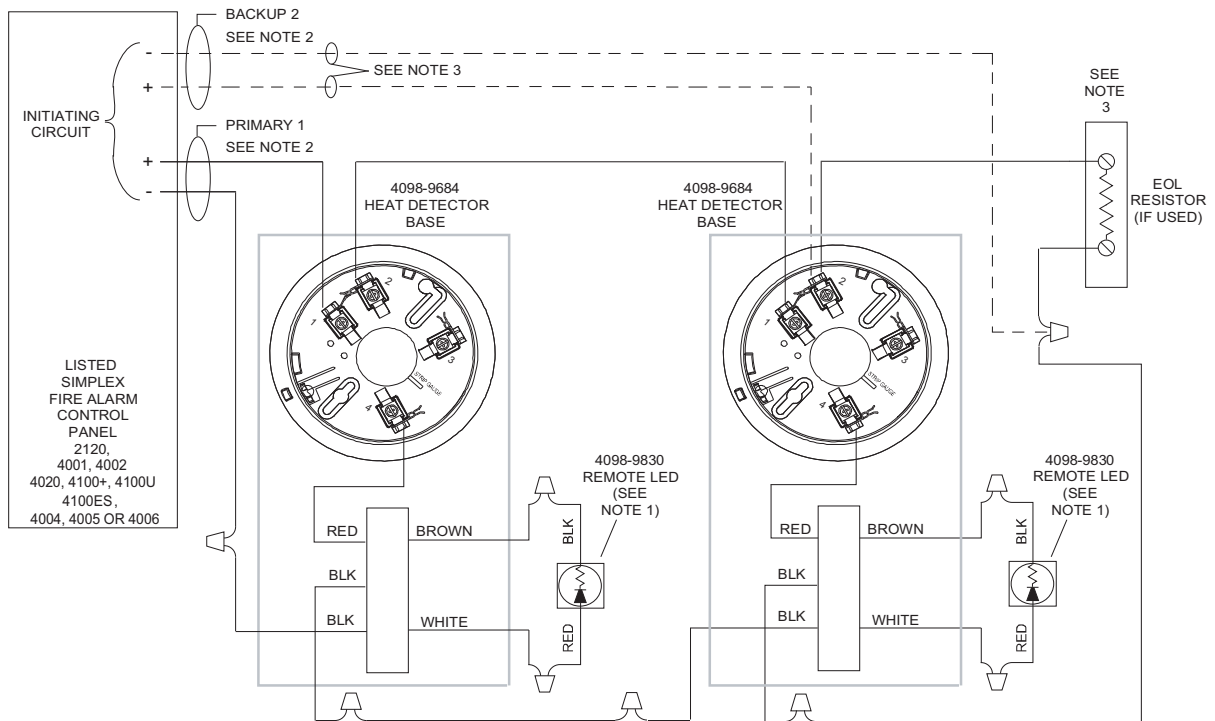

Figure 2-6. 4098-9684 Heat Detector LED Base Connections for Style B or D Initiating Circuits

Notes:

1. If used, 4098-9830 remote LED is polarized; observe color-coded wiring.
2. It is recommended that the Primary-1 and the Backup-2 lines be in separate wire runs and in compliance with local requirements.
3. For Style D initiating circuit, wire per dotted lines and do not use EOL resistor. If Style B initiating circuit, refer to wiring diagrams provided with the system panel for proper EOL resistor value.

Chapter 3

TrueAlarm Sensors, Sensor Bases, and QuickConnect Smoke Sensors

Introduction

This chapter contains general notes, specifications, and mounting information for the TrueAlarm Sensors, Sensor Bases and QuickConnect Smoke Sensors.



WARNING: Be sure that the location of each smoke sensor and each heat sensor has been planned per local and national fire codes (see NFPA 72).

Smoke sensor sensitivities are set and continuously monitored by the control panel. This functionality complies with NFPA 72. When functional testing of these sensors is required per NFPA 72, use the test methods described in Chapter 5 of this manual “Compatibility and Testing.”

Refer to NFPA 72 for application, test, and maintenance requirements.

The 4098-9733 heat sensor and 4098-9754 multi-sensor provide a Rate-of-Rise function that is software programmed and selectable at 15° F (8.3° C) or 20° F (11.1° C) per minute. The 4098-9733 and 4098-9754 also provide general temperature monitoring within the range of 32°-122° F (0°-50° C).

In this Chapter

Refer to the page number listed in this table for information on a specific topic.

Topic	See Page #
4098 TrueAlarm Sensors	3-2
4098 TrueAlarm Sensor Bases	3-3
4098 TrueAlarm QuickConnect Smoke Sensors	3-12

Table 3-1. 4098-9733 Spacing

Agency	Program Selection	Spacing
UL	135° F (57° C)	60 X 60 ft (18.3 X 18.3 m)
UL	155° F (68° C)	40 X 40 ft (12.2 X 12.2 m)
FM	135° F/155° F (57° C/68° C)	RTI = Quick 20 X 20 ft (6.1 X 6.1 m)
FM	135° F/155° F (57° C/68° C) with 15 or 20° F/min (8.3 or 11.1° C/min)Rate of Rise	RTI = Ultra Fast 50 X 50 ft (15.2 X 15.2 m)

4098 TrueAlarm Sensors

Specifications

Table 3-2. TrueAlarm Sensor Specifications

Sensor PID	4098-9714	4098-9717	4098-9733	4098-9754	4098-9746
Type of Sensor	Photoelectric	Ionization	Heat	Photo/Heat	Gas
Average Operating Current	80 μ A	80 μ A	6 μ A at 68° F (20°C) 13 μ A at 135° F (57° C)	90 μ A	50 μ A
UL Temperature Rating*	—	—	135° F (57° C)** 155° F (68° C)†	135° F (57° C)** 155° F (68° C)†	
Humidity Range (Non-Condensing)	10-95% RH	10-95% RH	10-95% RH	10-95% RH	15-95% RH (15-90% for long term exposure)
Air Velocity Range	0-2000 FPM	0-200 FPM	—	0-2000 FPM	0-1000 FPM

* Fixed temperature functions are software programmed and selectable from the UL temperature rating.
 ** UL Max. Ambient Ceiling Temp. of 100° F (38° C) at 3600 sq. ft of Max. Coverage.
 † UL Max. Ambient Ceiling Temp. of 100° F (38° C) at 1600 sq. ft of Max. Coverage.

Special Applications

- Smoke sensor sensitivities are set and continuously monitored by the control unit. The sensitivity range (setting) for the 4098-9714 and 4098-9754 sensor is 0.2%/FT to 3.7%/FT smoke obscuration. The sensitivity range (setting) for 4098-9717 sensors is 0.5%/FT to 1.3%/FT.
- The 0.2%/FT, 0.5%/FT, and 1.0%/FT settings for the 4098-9714 and 4098-9754 sensor and the 0.5%/FT and 0.9%/FT settings for the 4098-9717 sensor are for special applications only. The 0.2%/FT, 0.5%/FT, 0.9%/FT, and 1.0%/FT settings are very sensitive settings: **only use the 0.2%/FT setting when a sensor is located in a totally smoke-free and controlled temperature environment**, such as a computer room or telephone switching exchange.
- To determine if an area is suitable for the 0.2%/FT setting, set the sensitivity for the installed sensor at 1.5%/FT and monitor the peak values for **90 days**. If you record a peak value of 0.1%FT or higher during the 90 days, **do not use** the 0.2%/FT setting.
- To determine if an area is suitable for the 0.5%/FT setting, set the sensitivity for the installed sensor at 1.5%/FT and monitor the peak values for **90 days**. If you record a peak value of 0.25%FT or higher during the 90 days, **do not use** the 0.5%/FT setting.
- To determine if an area is suitable for the 0.9%/FT or 1.0%/FT setting, set the sensitivity for the installed sensor at 1.3%/FT (Ion) 1.5/FT (Photo) and monitor the peak values for **90 days**. If you record a peak value of 0.5% or higher during the 90 days, **do not use** the 0.9%/FT (Ion) or 1.0%/FT (Photo) settings.

Mounting

All sensors identified in Table 3-2 mount to a sensor base (refer to the “4098 TrueAlarm Sensor Bases” section of this chapter for more information). Use the following information and Figure 2-1 when mounting TrueAlarm sensors.

4098 TrueAlarm Sensor Bases

Introduction

TrueAlarm smoke/heat sensor bases are connected to a 2120 Multiplex Communicating Device Transponder (CDT), 4020, 4100+, 4100U, 4100ES, 4120, 4008, or 4010 panel by a single wire pair (MAPNET II/IDNet). The 4098-9792, -9789, 9793, 9796, 9797, and 9798 bases and their sensors obtain both power and data over MAPNET II/IDNet wiring. The 4098-9791 sensor base requires 24VDC power for relay operation and the 4098-9794 and 4098-9795 sensor base with sounder requires 24 VDC or Notification Appliance Circuit (NAC) power. The 4098-9791, -9794, -9795, and -9796 are NOT compatible with the 2120 CDT. The 4098-9793 is only compatible with the 4010, 4008, 4100U and 4100ES (except with 4100-3103 Quad Panel Isolator).

Specifications

The table below contains specifications for TrueAlarm Sensor Bases.

Table 3-3. TrueAlarm Sensor Bases Specifications

Sensor Base PID	4098-9789 (w/ Remote LED)	4098-9791 (w/ Relay and Remote LED)	4098-9792	4098-9793 (Isolator Base)	4098-9794 (Sounder Base)	4098-9795 (Multi-Sensor Sounder Base)	4098-9796 (Multi-Sensor w/ Remote LED)	4098-9797 (CO Sensor Base)	4098-9798 (CO Sounder Base)
Working Voltage (MAPNET II/IDNet)	24-40 VDC	24-40 VDC	24-40 VDC	24-40 VDC	24-40 VDC	24-40 VDC	24-40 VDC	24-40 VDC	24-40 VDC
24V Working Voltage (Relay or Sounder Power)	—	18 – 32 VDC	—	—	18 – 32 VDC	18 – 32 VDC	—	—	18 – 32 VDC
MAPNET II/IDNet Current *	400 μ A	400 μ A	400 μ A	500 μ A	400 μ A	500 μ A	500 μ A	450 μ A	500 μ A
24V Standby Current (Relay or Sounder)	—	270 μ A	—	—	270 μ A	270 μ A	—	—	270 μ A
24V Current (Relay or Sounder Activated)	—	28 mA	—	—	17 mA	20 mA	—	—	17 mA
LED Output	Yes	Yes	—	—	Yes	Yes	Yes	—	Yes
Sounder Output	—	—	—	—	88 dBA minimum	88 dBA minimum	—	—	88 dBA minimum

* MAPNET II/IDNet current with Photo Sensor plugged into Base

Setting the Base's Address

Each sensor base has a unique address. This address is associated with a custom label that identifies its physical location within a building. The base's address and location must match up with the address listed in the specification sheets of the 2120 Job Configuration Report or the Programmer's Report for the 4020, 4100+, 4100U, 4100ES, 4120, 4008, or 4010 System. See Figure 3-1 for DIP Switch location for 4098-9789, -9791, -9792, -9793, and -9796, Sensor Bases. See Figure 3-2 for DIP Switch location for 4098-9794, 4098-9795, -9797 and -9798.

Continued on next page

4098 TrueAlarm Sensor Bases, *Continued*

Setting the Base's Address

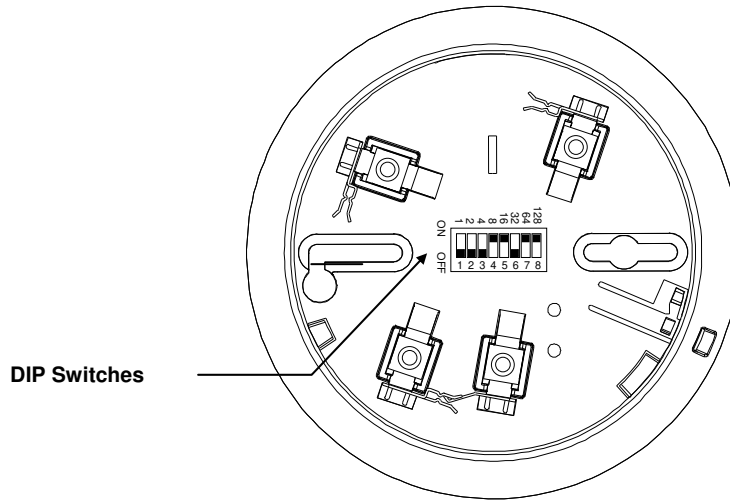

Figure 3-1. 4098-9789, -9791, -9792, -9793, -9796, Sensor Bases Location of DIP Switches

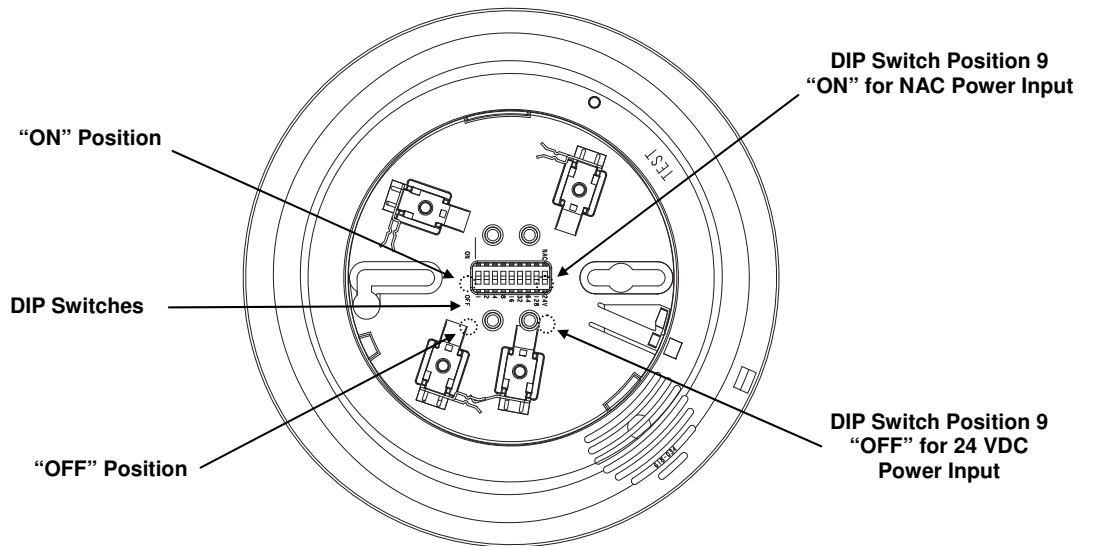

Figure 3-2. 4098-9794, 4098-9795, , 4098-9798 Sensor Bases Location of DIP Switches

Note: The 4098-9794 Sounder Base, 4098-9795 Multi-Sensor Sounder Base, and 4098-9798 Sounder Base have a 9-position DIP Switch. The first eight DIP Switches set the sounder base address. DIP Switch Position 9 is set to OFF or ON depending upon the sounder base power source. When the sounder base is connected to a 24 VDC power source, DIP Switch Position 9 is set to "OFF" and the 24 VDC power is supervised by the sounder base. When the sounder base is powered by the panel's Notification Appliance Circuit (NAC), DIP Switch Position 9 is set to "ON" and the power is supervised by the NAC and not the sounder base. The -9797 Base has the same layout, but doesn't offer sounder functionality. It uses only an 8-way DIP switch.

Continued on next page

4098 TrueAlarm Sensor Bases, *Continued*

Address Setting for the 2120 CDT System

- Using the 2120 Job Configuration Report, find the entry for the sensor base (4098-9792 and 4098-9789 only) you are about to install. The CUSTOM LABEL column provides the location while the DEVICE ADDRESS column provides the switch setting data.
- Using the switch setting data for the base you are installing, set the base's address. See Figure 3-1 for location of switches. Use a small screwdriver or pen to set the switches.
- Double-check the location of the sensor base and its address before proceeding to electrical installation (see Figure 2-1).

Address Setting for the 4010, 4020, 4100+, 4100U, 4100ES, 4008, or 4120 System

- Using the Programmer's Report for the 4020 (Figure 3-3), 4100+, 4100U, 4100ES, 4120, 4008, or 4010 (Figure 3-4), find the entry for the sensor base you are about to install. The device ADDRESS and CUSTOM LABEL are located in the SYSTEM POINT SUMMARY under "M." For example, Address M1-7 (for the 4100+, 4100U, 4100ES, 4120, 4008, or 4010 system) is circled in Figure 3-4. M1 is the addressable channel while -7 is the device address on the channel. For a base with Address M1-7, Address 7 must be set on the base's DIP Switches (SW1).
- Using the example given in Step 1 as guideline, set the base's address using the information in Figure 3-5. See Figure 3-1 and 3-2 for location of DIP Switches. Use a small screwdriver or pen to set the switches.
- Mark an address label with the appropriate address for your base by shading a label box for each base DIP Switch in the ON position. Then apply the label to the base near the base's DIP Switch.
- Double-check the location of the sensor base and its address before proceeding to electrical installation.

```

-----
924500LA rev: 1          SYSTEM POINT SUMMARY          Page 4
DOCUMENTATION          11.23.09, THU, 04-REV-07
-----
System Point Summary (ascending by zone name):          POINT SUMMARY
                                                         ZONE
-----
Zone Name Custom Label          Point Type Device PHIS
-----
I01      MULTI IO CARD 1 POINT I01      FULL      NORM
I02      MULTI IO CARD 1 POINT I02      FULL      NORM
I03      MULTI IO CARD 1 POINT I03      SIGNAL SIGM
I04      MULTI IO CARD 1 POINT I04      SIGNAL SIGM
M1-1     COMPUTER LAB BLDG 21
M1-2     3RD FLOOR EAST WING ROOM 18      SMOKE      GENLAM
M2-1     3RD FLOOR WEST WING ROOM 12      SMOKE      ALDRDT
I07      BASEMENT EAST WING ROOM 3 I07      EXTEND     NORM
-----
    
```

Figure 3-3. 4020 Programmer's Report

```

=====
HEH JOB: 1 2800 mode:1 rev:1          SYSTEM POINT SUMMARY          Page 4
BB:47:18, MON, 26-NOV-96
-----
System Point Summary (ascending by zone name):          POINT SUMMARY
                                                         ZONE
-----
Zone Name Custom Label          Device Point PHIS
Type Type Code
-----
M1-1     3RD FLOOR EAST WING ROOM 12      MBZM      HEAT
M1-2     3RD FLOOR EAST WING ROOM 13      MBZM      FIRE
M1-3     3RD FLOOR EAST WING ROOM 14      MBZM      HEAT
M1-4     3RD FLOOR EAST WING ROOM 15      ALDRDT     SMOKE
M1-5     3RD FLOOR EAST WING ROOM 16      ALDRDT     FULL
M1-6     3RD FLOOR EAST WING ROOM 17      ALDRDT     SMOKE
M1-7     3RD FLOOR EAST WING ROOM 18      PHOTO     SMOKE
M1-8     3RD FLOOR EAST WING ROOM 19      PENON     TROUBLE
-----
HEH JOB          DIGITAL PSEUDO POINT SUMMARY          Page 5
Job 1 2800 HEH JOB, Mode 1, Page 3188+, Rev 1
    
```

Figure 3-4. 4100+, 4100U, 4100ES, 4120, 4008, or 4010 Programmer's Report

Continued on next page

4098 TrueAlarm Sensor Bases, *Continued*

Address Setting for the 4010, 4020, 4100+, 4100U, 4100ES, 4008, or 4120 System

The figure below shows the address DIP Switch settings for the 4010, 4008, 4020, 4100+, 4100U, 4100ES and 4120 Systems. Refer to the "Compatibility and Testing" chapter of this publication for information on which devices are compatible with the various FACPs.

Note: The 4020, 4100+, 4100U, 4100ES, 4008, and 4120 systems support up to 127 devices on each of their MAPNET II channels. The 4010 supports up to 250 devices on its IDNet channel.

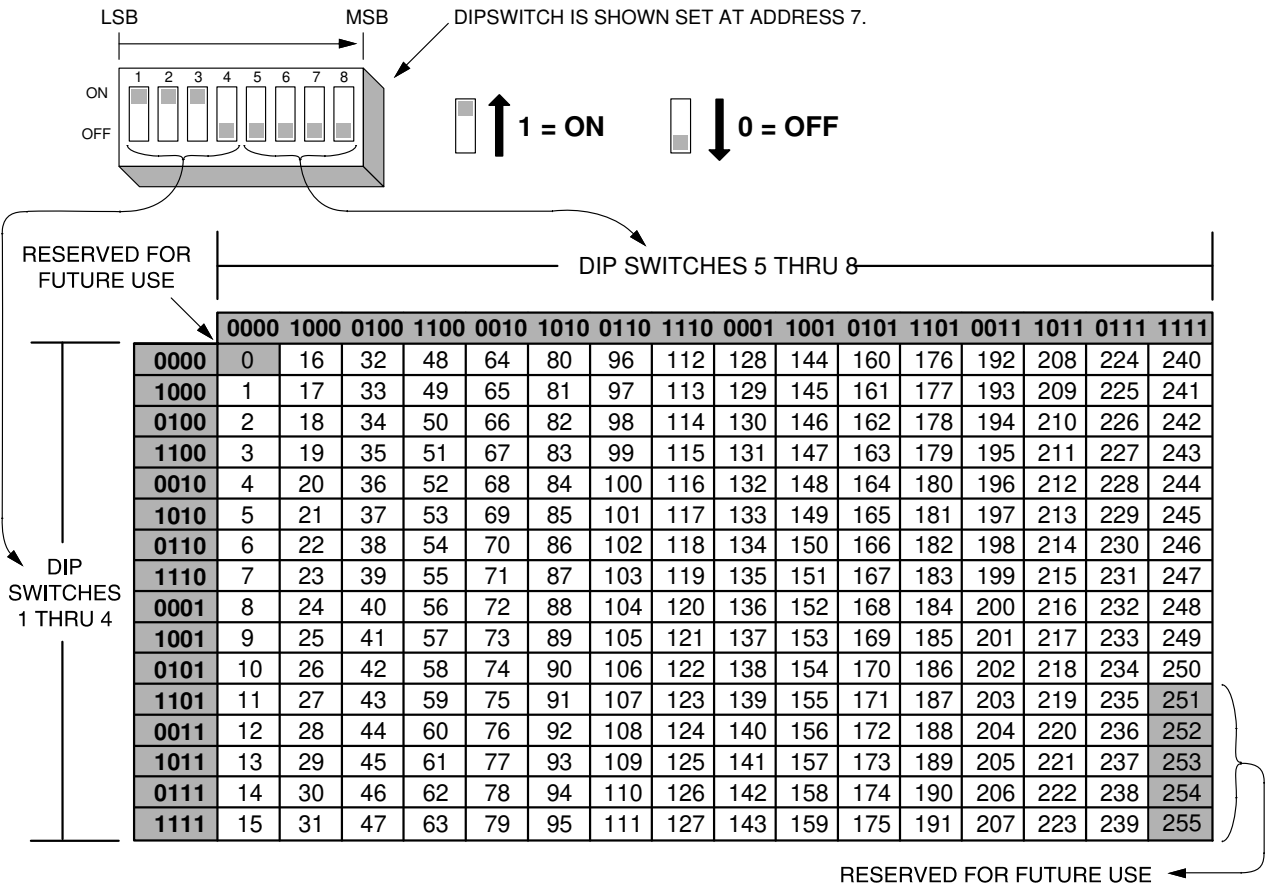

Figure 3-5. 4010, 4020, 4100+, 4100U, 4100ES, 4008, or 4120 MAPNET/IDNet Addresses

Continued on next page

4098 TrueAlarm Sensor Bases, *Continued*

Multi-Sensor Bases 4098-9795 and 4098-9796

The 4098-9795 and 4098-9796 Multi-Sensor Bases are **only** for use with the 4098-9754 multi-sensor and are **not** compatible with the 2120 CDT. Both bases have remote LED output and the 4098-9795 also has an integrated sounder similar to the 4098-9794 Sounder Base. The 4098-9795 and 4098-9796 Multi-Sensor Bases must be used with the 4098-9754 multi-sensor when connected to a 4010, 4020, 4100+, 4008, or 4120 system. When connected to a 4100U or a 4100ES the 4098-9754 multi-sensor can also be used with the 4098-9789, -9791, -9792, -9793, -9794, -9797, and -9798 bases.

The Multi-Sensor Base answers to two addresses, therefore the DIP Switch must be set for **even addresses only**. The even address is a photo sensor/sounder base (4098-9795) or a photo sensor/standard base (4098-9796), and the odd address (DIP Switch + 1) is a heat sensor/standard base. The figure below shows the allowable addresses for the Multi-Sensor Bases.



IMPORTANT: Switch Position 1 is not used and must always be OFF (0) for the Multi-Sensor Bases to function properly. The odd address immediately after the DIP Switch setting must not be used by any other sensor base or MAPNET/IDNet device.

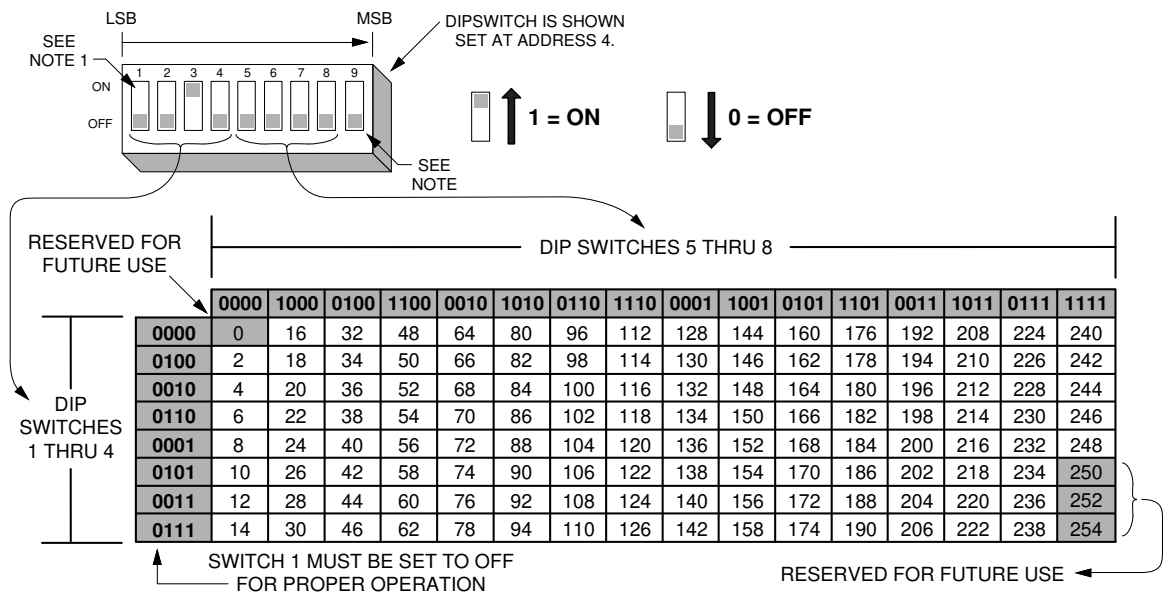

Figure 3-6. 4098-9795, -9796, 9798 Multi-Sensor Base DIP Switch Address Settings

Note: The 4098-9795 Multi-Sensor Sounder Base has a 9-position DIP Switch that is used for setting base address and selecting the sounder power source. See Figure 3-2 for DIP Switch location.

Wiring

Sensor bases are connected to the fire alarm control panel via a single wire pair for the 4098-9789, -9792, -9793, -9796, and -9797 and two pairs of wires for the 4098-9791, -9794, -9795, and -9798. Using Figure 3-7 as a reference, connect the bases to the MAPNET II/IDNet wire pair and 24V power (if used).



IMPORTANT: For additions to existing installations, remove power from the panel before wiring any bases to avoid damage to equipment.

Continued on next page

4098 TrueAlarm Sensor Bases, *Continued*

Wiring

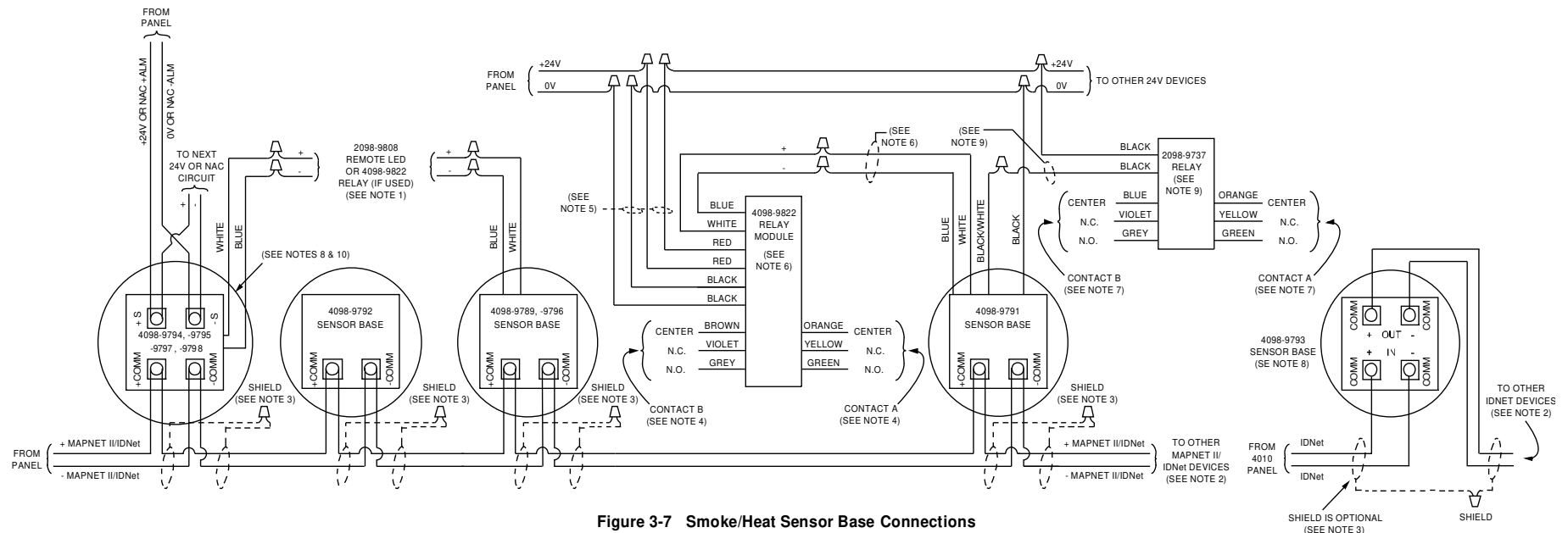

Figure 3-7 Smoke/Heat Sensor Base Connections

Notes:

1. Remote LED and relay wires are not supervised.
2. Maximum quantity of devices per circuit is 127 for 4020, 4100+, 4100U/4100ES (MAPNET), or 4120, 128 for the 2120 CDT panel, 200 for the 4008 panel, and 250 for the 4010 and 4100U/4100ES (IDNET) panel. Maximum quantity of 4098-9795 -9796 and -9797 Multi-Sensor bases is 63 with 4020, 4100+, 4100U, 4100ES and 4120, 100 for 4008 panel, and 124 for the 4010 panel. If the sounder output is coded (Temporal code, etc.) via MAPNET II/IDNet control see Note 10.
3. If shield is used, twist shield wires together and cap with wire nut. Shield should be insulated from electrical box.
4. Contact A or B: Dry, Form C - each rated 2 amperes at 24 VDC/0.5 amperes at 110 VAC, resistive.
5. 18 to 32 VDC, .008 amperes typical/.013 amperes max.
6. Do not use remote LED if the 4098-9822 relay module is used.
7. Contact A or B: Dry, Form C – Each rated at 3 amperes at 28 VDC/115 VAC, resistive.
8. Remove the protective tape over the CO Sensor on the 4098-9797 and -9798 bases only after the sensor head has been installed.
9. Maximum wire length between 4098-9791 sensor base and 2098-9737 relay module is 100 feet.
10. Maximum quantity of sensors with 4098-9794, -9795, and -9798 sounder bases limited to 43 if output is coded (Temporal code, etc.) via MAPNET II/IDNet control. If coding is performed via 24VDC or NAC circuit, see Note 2.

Continued on next page

4098 TrueAlarm Sensor Bases, *Continued*

Wiring

Figure 3-8 shows the wiring connections for the isolator sensor base. All screw terminals accept 14 to 18-gauge AWG solid or stranded. **Maximum torque should not exceed 12-inch-pounds.**



CAUTION: Do not loop wire under terminals. Break wire runs to provide supervision.

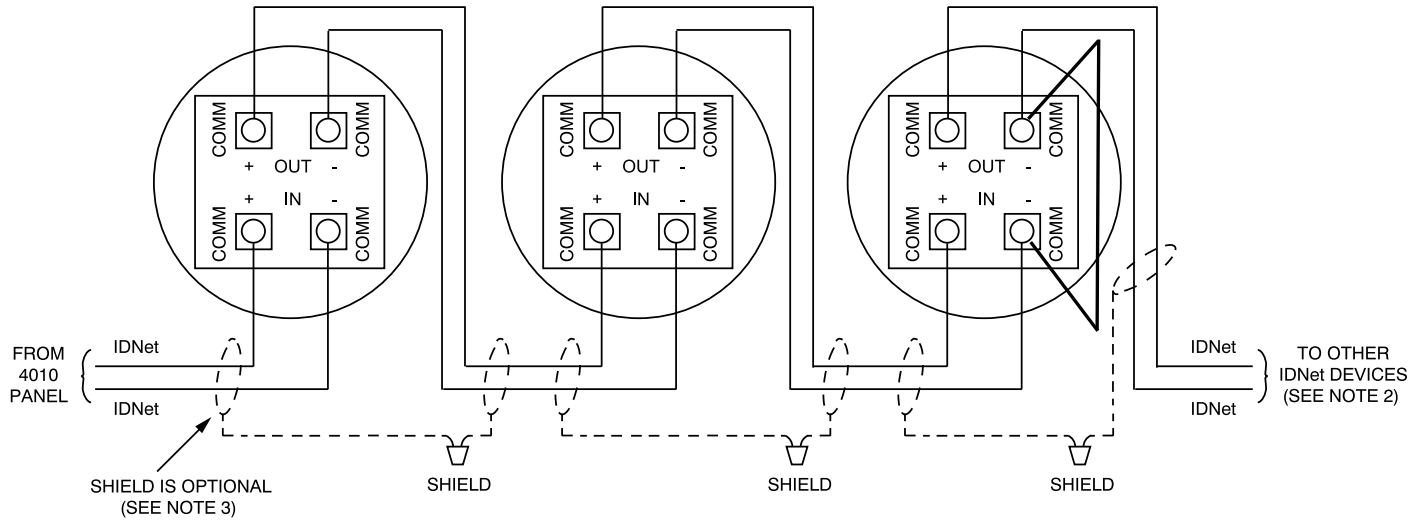

Figure 3-8. 4098-9793 Isolator Sensor Base Connections

Notes:

1. Isolator base compatible with 4010, 4100U, 4100ES or 4008 panel ONLY.
2. Maximum quantity of devices per circuit is 250 for 4010, 4100U and 4100ES panels.
3. If shield is used, twist shield wires together and cap with wire nut. Shield should be insulated from electrical box.

4098 TrueAlarm Sensor Bases, *Continued*

CRS Replacement Instructions

This section contains the instructions for the end-of-life replacement of the 4098-9746 CO Replacement Cartridge (CORC), in the CO SSD Bases (Carbon Monoxide Smoke Sensor and Detector Bases). Replacement is necessary due to normal component degradation over time. It is standard maintenance for the CO SSD Bases in order to prolong normal function without requiring base replacement.

Note: During installation, you may be exposed to live circuits - attention required to ensure personal safety and to avoid product damage.

Model number reference:

Model	Name
4098-9746	CORC Replacement
4098-9797	CO SSD Sensor Base
4098-9798	CO SSD Sounder Base

Removing the expired CORC

1. Remove sensor head (not shown) and set aside for later re-installation.
2. Insert a fine blade screwdriver into the slot, as shown below.



3. Gently free the CORC from the sensor base by pushing straight in. Do not pry. Remove the CORC and dispose.



Figure 3-9. Removing the CORC from the Sensor Base

Continued on next page

4098 TrueAlarm Sensor Bases, *Continued*

CRS Replacement Instructions

Installing the replacement CORC (refer to photo below)

1. Remove the replacement CORC from its packaging.
2. Hook the loop of the CORC on the tab in the outer rim of the base (center of the CORC below the CO sensor cylinder)
3. Gently rotate the CORC inward until it snaps onto the CO SSD Sensor Base.
4. Re-install the detector head.
5. Remove the dust cover from the CORC (shown to the side below).
6. The CORC replacement is complete.



Figure 3-10. Installing the replacement CORC

4098 TrueAlarm QuickConnect Smoke Sensors

Overview

This section contains general notes, specifications, and mounting information for the TrueAlarm QuickConnect Smoke Sensor shown in Table 3-4.



WARNING: Ensure that the location of each smoke sensor has been planned per local and national fire codes (see NFPA 72).

1. Smoke sensor sensitivities are set and continuously monitored by the control panel. This functionality complies with NFPA 72. When functional testing of these sensors is required per NFPA 72, use the test methods described in the “Compatibility and Testing” chapter of this publication. The sensitivity range (settings) of the 4098-9757 is 1.5%/ft to 3.7%/ft smoke obscuration.
2. Refer to NFPA 72 for application, test, and maintenance requirements.

Specifications

Table 3-4. TrueAlarm QuickConnect Smoke Sensor Specifications

Sensor PID	4098-9757
Type of Sensor	Photoelectric
Operating Current	500 μ A max.
Humidity Range (Non-Condensing)	10-95% RH
Air Velocity Range	0-2000 FPM
Working Voltage (MAPNET II and IDNet)	24-40 VDC
24V Working Voltage (Sounder Power)	—
Sounder Output	—
24V Standby Current (Sounder)	—
24V Current (Sounder Activated)	—
Remote LED Output	NO

Continued on next page

4098 TrueAlarm QuickConnect Smoke Sensors, *Continued*

Specifications

The 4098-9757 *QuickConnect2* sensor requires the 4098-9788 base.

The 4098-9757 *QuickConnect2* sensor is only compatible with the 4010, 4100U and 4100ES (with 4100-3106). The sensors obtain both power and data over IDNet wiring.

Setting the Sensor's Address

Each *QuickConnect* sensor has a unique address. This address is associated with a custom label that identifies its physical location within a building. The sensor's address and location must match up with the address listed in the Programmer's Report for the 4010, 4100U or the 4100ES.

Use the method described in the "4098 TrueAlarm Sensor Bases" section of this chapter to complete the sensor setup. Refer to the figure below for the location of the DIP Switches. Double-check the location of the *QuickConnect* sensor and its address before proceeding to electrical installation (see Figures 3-12 and 3-13).

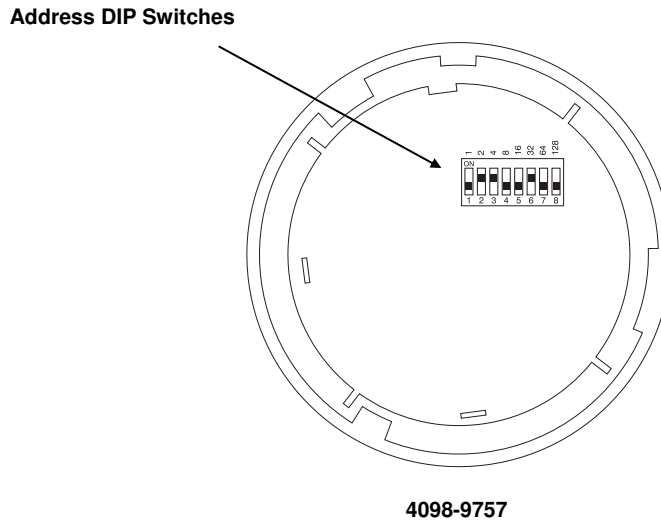

Figure 3-11. Location of DIP Switches on *QuickConnect* Sensor

Continued on next page

4098 TrueAlarm QuickConnect Smoke Sensors, *Continued*

Wiring



Use the following to wire the QuickConnect smoke sensors.

CAUTION: Do not loop wire under terminals. Break wire runs to provide supervision.

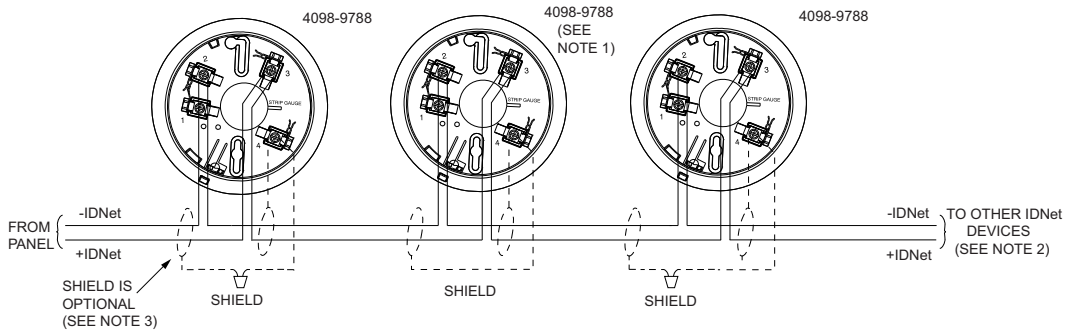

Figure 3-12. QuickConnect Sensor Connections

Notes:

1. 4098-9757 QuickConnect sensor uses the 4098-9788 base.
2. Maximum quantity of devices per IDNet circuit is 250 for the 4010, 4100U and 4100ES (with 4190-3106) panel.
3. If shield is used, twist shield wires together and cap with wire nut. Shield should be insulated from electrical box.

Chapter 4

Accessories

Introduction

This chapter covers relay module accessories.

In this Chapter

Refer to the page number listed in this table for information on a specific topic.

Topic	See Page #
Relay Module Accessories	4-2

Relay Module Accessories

2098-9737 Relay Module Wiring

The 2098-9737 Relay module is used with 4098-9791 sensor base. Install the relay module using Figure 3-7 and the figure below as a reference.

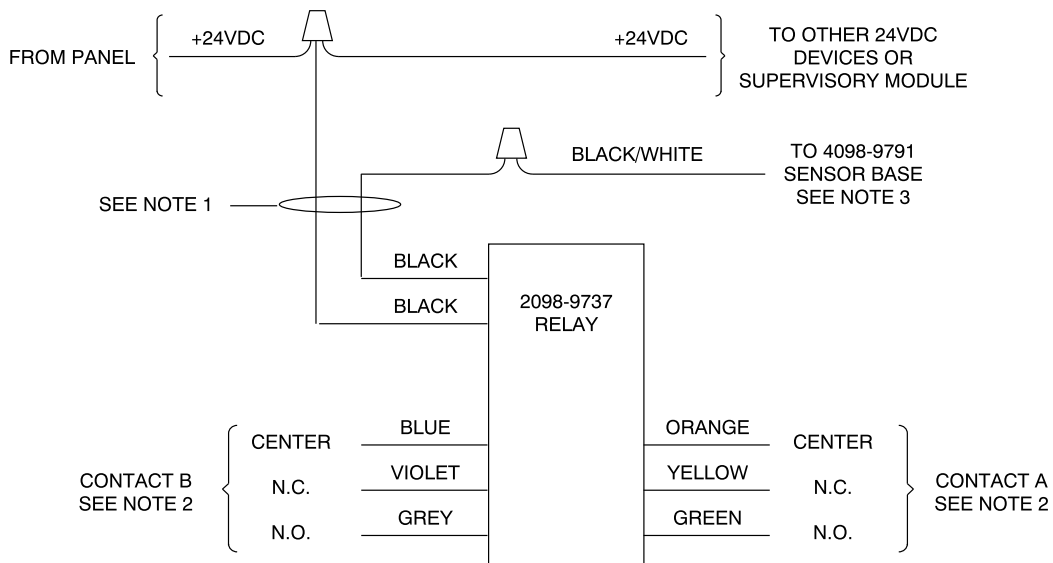

Figure 4-1. 2098-9737 Relay Module Wiring

Notes:

1. 18 to 32 VDC 24 mA typical/35 mA maximum.
2. Contact A or B: dry, Form C, each rated 3 amps at 28 VDC/115 VAC, resistive.
3. Maximum wire length between sensor and relay module is 100 feet.

Continued on next page

Relay Module Accessories, *Continued*

4098-9822 Relay Module Wiring



The 4098-9822 Relay Module is used with the 4098-9789, -9791, -9794, -9795, and -9796 Sensor Bases. Install the relay module using Figure 3-7 and the figure below as a reference.

IMPORTANT: Do not use a remote LED if using the 4098-9822 relay module. The 4098-9822 relay module is not supervised and should only be used for non-critical supplementary functions. There is a limit of ten control outputs activated on a MAPNET II/IDNet channel. If the channel capacity is exceeded, the relay module may not function properly.

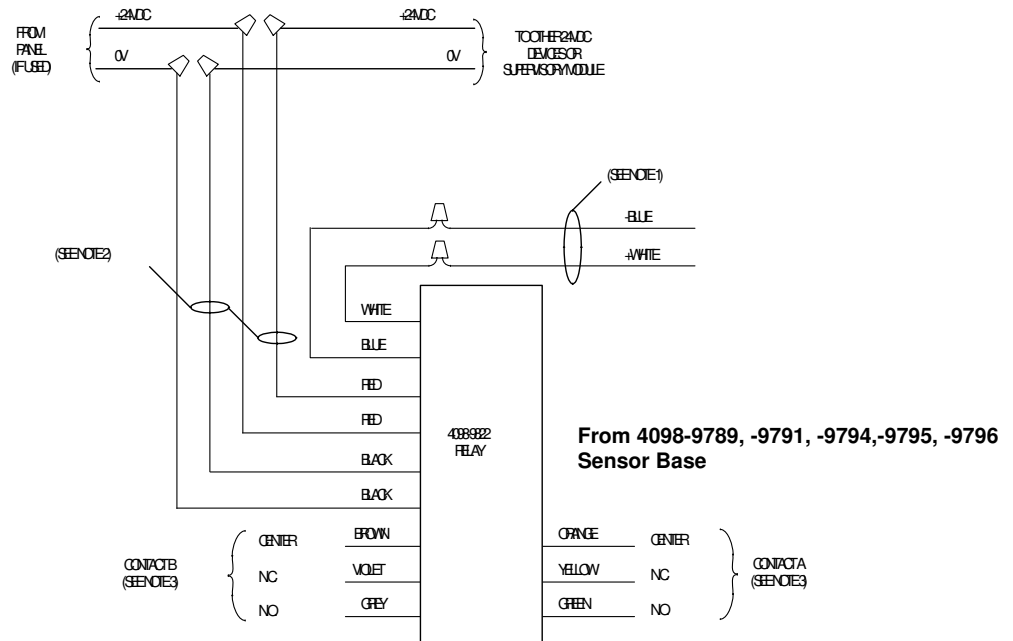

Figure 4-2. 4098-9822 Relay Module Wiring

Notes:

1. Do not use remote LED.
2. 18 to 32 VDC, .008 amps typical / .013 amps. Maximum.
3. Contact A or B: Dry, Form "C" - each rated 2 amps resistive at 24 VDC/0.5 amps at 110 VAC, resistive.

Continued on next page

Relay Module Accessories, *Continued*

Relay Module Installation

Install the relay module using the following steps:

1. Mount a 1-1/2 inch (3.81 cm) extension ring (not supplied) to an octagonal or square electrical box (not supplied). The extension ring is required to meet the minimum box volume requirement (32.3 cu. inch/529.4 cu. cm) for relay module installation.
2. Mount relay module inside extension ring directly behind base and sensor. **Do not mount remotely.** See Figure 4-1 or 4-2 for relay module connections.

Note: Use the exact configuration of electrical box (square or octagonal) with extension to mount sensor base when installing the relay module.

Remote LED Module

The 2098-9808 Remote LED Module is available for the 4098-9789, -9791, -9794, -9795, -9796 Sensor Bases.

Use the figure below as a reference when installing the Remote LED Module to a sensor base.

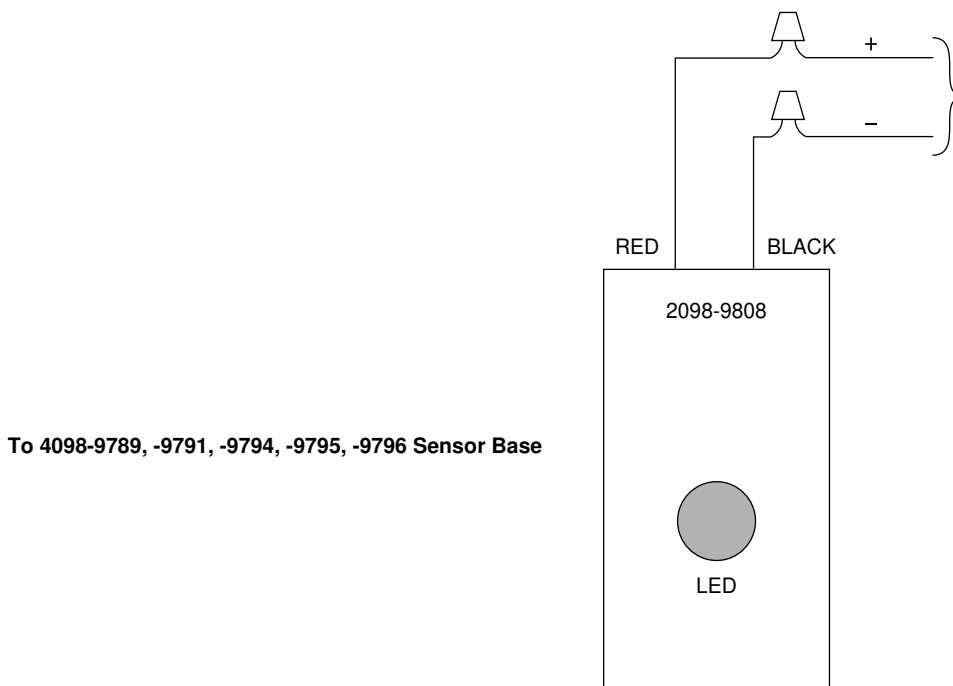

Figure 4-3. 2098-9808 Remote LED Module Wiring

Chapter 5

Compatibility and Testing

Introduction

This chapter covers the compatibility of 4098 Sensors, Detectors, and Bases. Maintenance and testing are also covered.

In this Chapter

Refer to the page number listed in this table for information on a specific topic.

Topic	See Page #
Compatibility	5-2
Maintenance and Testing	5-4
Cleaning	5-8
Trouble Indications	5-9
Fire Alarm Trouble and Maintenance Log	5-11

Compatibility

Compatibility for 4098 Detectors and Detector Bases

This section describes the compatibility between FACPs, detectors, and detector bases.

Table 5-1. 4098 Detector and Detector Base Compatibility

Detectors	Compatible 2-Wire Detector Base	System	Max. Quantity of Bases per Initiating Circuit
4098-9601	4098-9788	2120 ET/FADM	25
4098-9602	4098-9684	2120 FABT/VPBT	18
4098-9603	(LED base for Heat Detectors Only)	2120/4100+ ZAM	20
4098-9605		4001	18
4098-9612		4002	30
4098-9613		4020	30
4098-9614		4100ES/4100U/4100+/4120/UT	30
4098-9615		4004/4005	20
		4006	30
		4004/4005 High Current	30
		4098-9683	(Relay base not used with 4004 and 4005 Low Current systems)

Notes:

1. Relay operation cannot be guaranteed unless it is the only device on that zone.
2. Panel compatibility identification marker is model number of the module or panel.
3. Detector compatibility identification marker is model number found on detector label.
4. For detailed interconnection data, see wiring diagrams for specific panels.
5. For additional compatibility listings see 579-832 for 2-wire detector compatibility charts.

Continued on next page

Compatibility, Continued

Compatibility for 4098 Detectors and Detector Bases

This section describes the compatibility between FACPs, sensors, and sensor bases.

Table 5-2. 4098 Sensor and Sensor Base Compatibility

Sensors	Compatible Bases	Max. Quantity of Devices Per Circuit
4098-9714 4098-9717 4098-9733	4098-9789 4098-9791 4098-9792	MAPNET II: 127 (4020), 127 (4100+) 127 (4120), 127 (4100U), 127 (4100ES) Addresses 1-127
4098-9714 4098-9717 4098-9733	4098-9789 4098-9792	128 (CDT TrueAlarm) Addresses 0-127
4098-9714 4098-9717 4098-9733	4098-9789 4098-9791 4098-9792 4098-9793 4098-9797 (4100U/4100ES only)	IDNET: 250 (4010), 250 (4100U), 250 (4100ES) Addresses 1-250
4098-9714 4098-9733	4098-9789 4098-9791 4098-9792 4098-9793	IDNET: 200 (4008) Addresses 1-200
4098-9714 4098-9717 4098-9733	4098-9794 (See Note 5) 4098-9798 (See Note 5) (4100U/4100ES, IDNet only)	MAPNET II: 127 (4020), 127 (4100+) 127 (4100U), 127 (4100ES), 127 (4120) Addresses 1-127 IDNET: 250 (4010), 250(4100U), 250 (4100ES) Addresses 1-250
4098-9754	4098-9795 (See Note 5) 4098-9796	MAPNET II: 63 (4020, 4100+, 4100U, 4100ES, 4120) Addresses 2 to 126 IDNET: 124 (4010), 124 (4100U), 124 (4100ES) Addresses 2 to 248
4098-9754	4098-9792 4098-9789 4098-9791 4098-9794 (See Note 5) 4098-9797 4098-9798 (See Note 5)	IDNET: 250 (4100U), 250 (4100ES) Addresses 1-250
4098-9757	4098-9788	IDNET: 250 (4100U/4100ES with 4100-3106) 250 (4010) Addresses 1-250
4098-9746	4098-9797 4098-9798 (See Note 5)	IDNET: 250 (4100U), 250 (4100ES) Addresses 1-250

Notes:

- For detailed interconnection data, see wiring diagrams for specific panels.
- Panel compatibility identification marker is model number of the module or panel.
- Sensor compatibility identification marker is model number found on sensor label.
- 4098-9754 sensor NOT compatible with bases that have a RED DOT located in sensor mounting area.
- Maximum quantity of 4098-9794 Sounder Bases, 4098-9795 Multi-Sensor Sounder Bases, and CO Sounder bases (4098-9798) when output is coded via MAPNET II/IDNet control (Temporal Code) is 43. If coding is performed via 24 VDC or NAC circuit, use limits specified in Table 5-2.

Maintenance and Testing

Maintenance

The minimal requirement for detector and sensor maintenance should consist of clearing surface dust by using a vacuum cleaner. Cleaning programs should comply with NFPA and local environments. Cleaning of the internal chamber should only be done by a qualified technical representative.

For service, return to your local branch office.

Testing

Smoke sensor sensitivities are set and continuously monitored by the control unit. Dirty or out-of-range sensors are annunciated by the control unit. This functionality complies with NFPA 72.

Note: When testing detectors/sensors, refer to NFPA 72, or contact your local branch office.



CAUTION: Before functionally testing the detectors/sensors, be sure to disconnect the city connection, releasing devices, and extinguishing systems (or for the 4020, 4010, 4100+, 4100U, 4100ES, 4006, 4008, or 4120 panel, put the panel in the Walk Test mode).

Preferred Method of Testing Smoke Detectors/Sensors

NFPA minimally requires annual functional testing of smoke detectors/sensors at their installed location. To perform this annual test, use the Solo 336 Aerosol Smoke Dispenser.



IMPORTANT: After testing detectors, reset the fire alarm panel to restore the fire alarm system to normal status. After testing sensors, you must clear the peak values.

Test Equipment Available

The following test equipment is available:

- **553-760:** Test and Removal Tool – attached to Mr. Longarm 4 ft. pole (Item #7508) or 6 ft. pole (Item #7512).
- **553-761:** Heat Detector/Sensor Removal Adapter (use with 553-760).
- **553-635:** Aerosol spray, Simplex Dry Smoke.
- **553-805:** Removal Adapter Head Attachment (attaches to the 553-760 tool).
- **553-810:** Magnet Tester – attached to Mr. Longarm 4 ft. pole (Item #7508) or 6 ft. pole (Item #7512).
- **553-832:** Ion Detector Test Cable.

Also available are the:

- Gemini Sensitivity Tester (Model 501 or 502).
- Solo 336 Aerosol Smoke Dispenser –attached to either the Solo 100 (15 ft.) telescopic fiberglass pole or the Solo 101 (4 ft.) fiberglass pole.
- Solo A4 Aerosol Spray.
- Solo Red Cup (709-024). Use to hold the 553-635 Aerosol Spray Can.
- Solo (708-021) Adapter for Solo Poles. Use to adapt 553-760 Test and Removal Tool to the Solo Pole.
- TrueTest 801 – Smoke Detector Sensitivity Test Equipment.
- Smoke 400 – Smoke aerosol for TrueTest.

Note: The TrueTest 801 is the only tester to be used with the 4098-9797 and 4098-9798 bases.

Continued on next page

Maintenance and Testing, *Continued*

Alternate Method for Testing Sensors

The following test method is suitable for functional checks of sensor bases or QuickConnect sensors during installation; however, testing with smoke must be performed to comply with NFPA requirements.

For all sensor bases, position the 553-810 Magnet Tester $\frac{1}{2}$ " to $\frac{3}{4}$ " counterclockwise from the visible LED found on the sensor base, (see the figure below).

For the 4098-9757 QuickConnect2 photo sensor, position the 553-810 Magnet Tester as shown in Figure 5-2.

Testing a sensor with a magnet reports a value of 255 for actual / peak (exception 4010 panel, 4100U panel and 4100ES panel). Clear the peak value after testing.

Note: For 4098-9795 and 4098-9796 Multi-Sensor Bases both photo and heat address (even and odd) must alarm.



Figure 5-1. Magnet Test Location for 4098-9789, -9791, -9792, -9793, and -9796 Sensor Bases using 553-810 Magnet Tester

Magnetic Test for Photoelectric Detectors

The 4098 photoelectric detectors may be tested by placing a magnet above the location indicated by a “|” mark embossed on the cover (see Figure 5-2) **for four (4) seconds**. Use the Magnetic Tester (Part No. 553-810), Table 5-3, and the following information to test detectors.

Table 5-3 describes the LED reaction during Normal and MAG TEST modes to the Normal, More Sensitive, Less Sensitive, and Non-Functional states of the detector.

Continued on next page

Maintenance and Testing, *Continued*

Magnetic Test for Photoelectric Detectors



Figure 5-2. Magnet Test Location for 4098-9601, -9602, -9603, -9605 Smoke Detectors using 553-810 Magnet Tester

Table 5-3. MAG TEST/Normal Modes - States and Reactions

STATE	Normal Mode (LED flashes every 4 secs.)	MAG TEST Mode		
		LED Flashes Quickly 6 Times	LED Flashes Slowly 4 Times	Latches in Alarm Mode/LED stays "ON"
Normal	X			X
More Sensitive	X	X		X
Less Sensitive	X		X	X
Non-Functional			X	

When placing the magnet at the location indicated by a “|” mark embossed on the cover, the visible LED flashes indicating the detector's condition. The following are descriptions of what you should see when using the MAG TEST.

- **NORMAL** - When in MAG TEST, the detector latches into alarm if the detector is within calibration range and the visible LED stays ON.
- **MORE SENSITIVE** - When in MAG TEST, if the detector is more sensitive than the maximum calibration, the visible LED *quickly* flashes, twice a second. Following the sixth flash, the detector latches into alarm and the visible LED stays ON.
- **LESS SENSITIVE** - When in MAG TEST, if the detector is less sensitive than the minimum calibration, the visible LED *slowly* flashes four times, once every two seconds. Following the fourth flash, the detector latches into alarm and the visible LED stays ON.
- **NON-FUNCTIONAL DETECTOR** - If the detector is less sensitive than the minimum allowable sensitivity or if there is a fault in the temperature sensing circuit (4098-9602), the visible LED does not flash normally. When in MAG TEST, the visible LED *slowly* flashes four times, once every two seconds. After the fourth flash, the detector does NOT latch into alarm and the LED stops flashing and turns OFF.

If the detector is out of the normal operating range, it should be cleaned. If the detector still indicates as other than normal sensitivity, replace the detector.

Continued on next page

Maintenance and Testing, *Continued*

Magnetic Test for Ionization Detectors

The 4098 Ionization Detectors may be tested with a magnet to verify proper operation of the Fire Alarm Control Panel.

Note: When ionization detectors alarm, the red LED indicator activates and latches into the ON position.

Place a magnet against the detector's side (over the location marked by a “|” on the head of the ionization detector) and hold for **ten seconds** to activate an internal reed switch. Use the Magnet Tester (Part No. 553-810).

Ion Detector Sensitivity Test

Plug the 553-832 Ion Detector Test Cable into the Detector's sensitivity voltage pins located on the Ion Detector Head. Perform the following steps to test the Ion detector's sensitivity:

1. Connect a 10M/V digital voltmeter to the 553-832 test cable, connect the negative terminal of the voltmeter to the red wire of the test cable and connect the positive terminal of the voltmeter to the white wire of the test cable. The black wire of the 553-832 test cable is not used.
 2. The voltage measured by the voltmeter should be within 0.2 and 0.8 volts. Detectors outputting a voltage outside this range should be cleaned or replaced.
 3. If the Ion Detector voltage output is outside of the range, it should be removed and cleaned as described in the cleaning section. Re-check the voltage measurement on the Ion Detector; if the Ion Detector is still outside the voltage range after cleaning, replace the device.
-

Cleaning

Introduction



If the device's sensitivity is other than what is marked on the device's label, clean the device using a source of oil-free, filtered, compressed air such as Dust-Off, Tech Duster, etc.

CAUTION: Notify appropriate building personnel prior to removing any detectors/sensors from service.

Photoelectric Smoke Detector/Sensor Cleaning

Blow the compressed air through the open vents around the device so that air enters and cleans the black chamber cover/insect screen assembly (Part No. 677-224) located beneath the white protective cover.

If the device's sensitivity is still other than what is marked on the device's label, replace the device.

Special Considerations for Ion Detectors and Sensors

Note: Do not remove the Ion Detector/ Sensor protective cover.

Blow compressed air through the open vents around the device so that air enters and cleans the black chamber cover assembly located beneath the white protective cover. If the device sensitivity is still outside the marked range replace the device and return the failed device to 130 Perinton Parkway, Fairport, NY 14450-9199.



IMPORTANT: Once cleaned, the detector/sensor should be tested with smoke per NFPA 72.

Trouble Indications

Trouble Indications for TrueAlarm Sensors

The TrueAlarm smoke sensor is a measuring device that sends data regarding smoke density to the 4010, 4020, 4100, 4100+, 4100U, 4100ES, 4008, and 2120 fire alarm control panels (FACPs). The TrueAlarm heat sensor operates in a similar fashion, but sends temperature data instead of smoke density data. The FACP uses this data to determine whether a trouble has occurred.

The TrueAlarm sensor has two automatic trouble indications:

- Dirty
- Excessively Dirty

A “Smoke Sensor Dirty” trouble condition is reported any time the average value on an individual sensor reaches a set threshold value. At this time, the FACP is still compensating for environmental factors and is holding the set sensitivity level.

A “Smoke Sensor is Excessively Dirty” trouble condition is reported anytime the average value of an individual sensor reaches a slightly higher set threshold level. At this point, the FACP can no longer compensate for environmental factors, and the sensitivity level may begin to drift. Although an “excessively dirty” trouble is reported, the sensor continues to operate and reports an alarm condition when one is detected.

In addition to the two automatic trouble conditions, the FACPs have digital pseudo points that must be turned ON to allow a TrueAlarm sensor that is close to being a dirty sensor to report as if it is “almost dirty.” This is useful when maintenance is being scheduled for dirty sensors, as it provides a means of seeing if other sensors are approaching a dirty state.

The table below shows your responsibilities when certain trouble indications occur.

Table 5-4. TrueAlarm Troubles and Descriptions

Trouble Indication	Description
Almost Dirty	Using the front panel keys, it is possible for a technical representative to turn ON a digital pseudo point in the FACP that allows an “almost dirty” sensor to report a trouble. Although the “almost dirty” sensor is holding its sensitivity level, you can schedule maintenance for the sensor before the dirty sensor trouble occurs.
Dirty	A “dirty” indication means that the sensor is holding its sensitivity level, but that you should schedule maintenance for the sensor. Clean the sensor as required and, when necessary, call your local branch office for service.
Excessively Dirty	The “excessively dirty” indication means that the sensor is no longer compensating for dirt and dust. Because nuisance alarms are possible with this condition, sensors must be cleaned or replaced immediately. When necessary, call your local branch office for service.
Self-Test Abnormal	All FACP system sensors are automatically tested once every minute. When a sensor fails to report properly to the FACP, a “Self-Test Abnormal” condition occurs. Since the sensor is not working properly, it must be replaced. Replace it, or call your local branch office for service.
Expired	The FACP panel generates an Expired trouble to notify the user that a replacement sensor is required. To clear the trouble, a new CRS with a valid date must be installed, and a hardware reset of the FACP panel must be performed.

Continued on next page

Trouble Indications, *Continued*

Table 5-5. Sensor's Analog Value

The panel will automatically indicate when a sensor is out of its sensitivity calibration. If the sensor has an analog value below what is listed in the table, the sensor is within its sensitivity setting.			
Sensor's Analog Value			
Type	Almost Dirty	Dirty	Excessively Dirty
Photo	115	120	135
Ion	135	140	155
To view a Sensor's analog value, refer to your panels operating instructions			

Index

- 2
- 2120 CDT System
 - address setting, 3-5
- 2-Wire Relay Base Connections, 2-12
- 4
- 4010 System
 - address setting, 3-5
- 4020 System
 - address setting, 3-5
- 4100+ System
 - address setting, 3-5
- 4100U/ 4100ES System
 - address setting, 3-5
- 4120 System
 - address setting, 3-5
- 4-Wire Base Connections, 2-13
- A
- Accessories, 4-1
- Authorities Having Jurisdiction, 2-2
- B
- Base compatibility, 5-2
- Bases
 - 4098, 2-8
 - wiring, 2-10
- C
- Cautions and Warnings, iv
- Cleaning, 5-8
- CO Sensor Bases, 1-8
 - CRS, replacing, 3-10, 3-11
- Common Code Requirements, 2-8
- Compatibility, 5-1
- Copyrights, iii
- CRS
 - replacing, 3-10, 3-11
- D
- Detector compatibility, 5-2
- Detectors
 - placement, 1-5
 - Wall and Ceiling Mounted, 1-4
 - where not to place, 1-6
 - where to place, 1-3
- E
- Environmental conditions, 1-6
- H
- Heat Detectors
 - 4098, 2-5
 - fixed temperature, 2-5
 - LED Base Connections, 2-14
 - models, 2-6
 - ROR Temperature, 2-5
 - specifications, 2-6
 - types, 2-5
- HVAC Systems, 1-3
- I
- IDNet Addresses, 3-6
- Ionization Detectors
 - testing, 5-7
- Isolator Sensor Bases
 - connections, 3-9
- M
- Magnetic Test, 5-5
- Maintenance, 5-4
- MAPNET Addresses, 3-6
- Mult-Sensor Bases
 - DIP Switch settings, 3-7
- Multi-Sensor Bases, 3-7
- N
- NFPA 70, 1-3
- NFPA 72, 1-2, 1-3, 1-4, 2-2, 2-8, 3-1
- NFPA 90A, 1-3
- O
- Operation
 - principles of, 1-8
- P
- Photoelectric Detectors
 - testing, 5-5
- Programmer reports, 3-5
- Q
- QuickConnect Smoke Sensors, 3-12
 - DIP Switch settings, 3-13
 - specifications, 3-12
- R
- Rate-of-rise, 1-8
- Relay module
 - 2098-9737 wiring, 4-2
 - 4098-9822 wiring, 4-3
 - accessories, 4-1
 - installation, 4-4
- Remote LED module, 4-4
- S
- Sensor base compatibility, 5-3
- Sensor Compatibility, 5-3
- Sensors
 - Wall and Ceiling Mounted, 1-4
 - where not to place, 1-6
 - where to place, 1-3
- Smoke Detector Application, 1-2
- Smoke Detectors
 - 4098, 2-2
 - limitations, 2-2
 - mounting, 2-4
 - photoelectric, 1-8
 - specifications, 2-3
- Smoke Sensor Application, 1-2
- Smoke Sensors
 - photoelectric, 1-8
- Style B or D Initiating Circuits, 2-11
- T
- Test Equipment, 5-4
- Testing, 5-4
 - detectors and sensors, 5-4
- thermistors, 1-8
- Trademarks, iii
- Trouble and Maintenance Log, 5-10

Trouble Indications, 5-9
TrueAlarm Concepts, 1-8
TrueAlarm QuickConnect Smoke Sensors,
3-12
TrueAlarm Sensor Bases
4098, 3-3
setting the address, 3-4
specifications, 3-3
,
TrueAlarm Sensors
DIP Switch location, 3-4
special applications, 3-2
TrueAlarm Sensors, mounting, 3-2

574-709
Rev. T



FIRE • SECURITY • COMMUNICATIONS • WORLDWIDE SALES & SERVICE

© 2008-2011 SimplexGrinnell LP. Specifications and other information were current as of publication and are subject to change without notice.

firealarmresources.com